

## Be Ready for *Bluetooth*<sup>™</sup>

Make sure you are ready for the complexities of testing *Bluetooth* designs.

Isabelle Duverne, Agilent Technologies

---

*Bluetooth* wireless technology is an open specification for a wireless personal area network (PAN). It provides limited-range wireless connectivity for voice and data transmissions between information appliances, eliminating the need for interconnecting cables. Unique among most wireless communications systems, *Bluetooth* enables ad hoc networking among devices without the need for infrastructure such as base stations or access points. *Bluetooth* is named after a tenth-century Danish king who is credited with uniting Denmark and Norway; the twenty-first-century version unites devices through its wireless communications link.

*Bluetooth* wireless technology will allow seamless interconnectivity among devices. Your computer will synchronize files and databases with your personal digital assistant (PDA) simply because you carried the PDA into the vicinity of the PC. Laptop PCs could access e-mail by linking to nearby mobile phones or perhaps with a *Bluetooth*-enabled airport lounge Internet-access device. Wireless headsets will simplify hands-free operation of mobile phones as a convenient and safe way to talk while driving. The potential of this technology is limitless when you consider the growing number of information appliances that would benefit from wireless connectivity.

In its most elementary form, *Bluetooth* is defined as a global specification for wireless connectivity. It operates in the uncoordinated, interference-dominated RF environment of the Industrial, Scientific, and Medical (ISM) radio band, and employs frequency-hopping spread-spectrum (FHSS) technology. Because it is intended to replace cables, design emphasis is on very low power, extremely low cost, and robust operation.



Agilent Technologies

*Bluetooth* radios may operate as either master or slave units. A master can be actively communicating with up to 7 slaves, while another 200 or more slaves can be registered in one of three non-communicating, power-saving modes. This area of control is called a piconet. A master in one piconet can be a slave to a master in a different piconet. Also, multiple masters from different piconets can control a single slave. This network of piconets is referred to as a scatternet. **Figure 1** depicts two piconets forming a scatternet. Units that are not part of either piconet remain in standby mode.

Each *Bluetooth* channel is 1 MHz wide. The frequency hopping occurs over the 79 channels. The modulation in a *Bluetooth* system is two-level frequency shift keying (2FSK). This is a digital modulation format in which the modulated carrier shifts between two frequencies representing 1 and 0. As a result, 2FSK modulation provides one bit of data per symbol. Unlike many other forms of digital modulation, amplitude and phase are not of primary concern in this type of modulation scheme.

The *Bluetooth* band is divided into time slots; each slot corresponds to an RF hop frequency. In the time-division duplex

(TDD) scheme used, the master transmits in even-numbered time slots, and the slave in odd-numbered time slots. Voice bits or data bits within piconets are transmitted in packets. Packets transmitted by the master or the slave may extend over one, three, or five time slots. A packet, diagrammed in **figure 2**, contains an access code, a header, and a payload. The access code

consists of a preamble, a sync word, and an optional trailer. The header contains piconet address and packet information, and the payload carries the user's voice or data information.

A *Bluetooth* system consists of a radio unit, a baseband link control unit, and link management software. It also includes

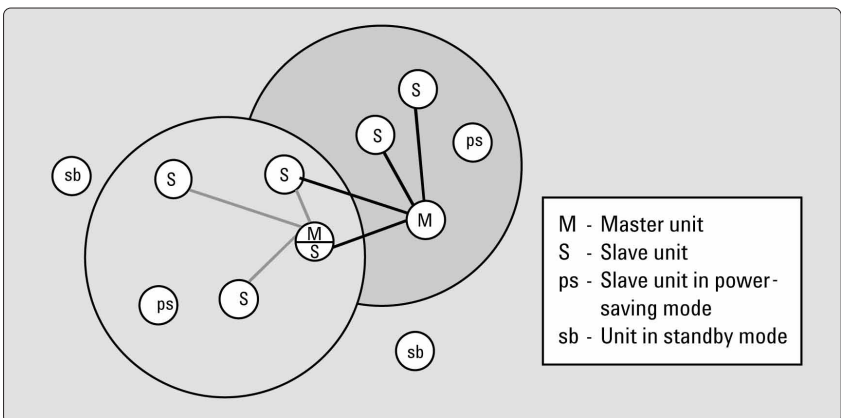

**Figure 1.** Network topology

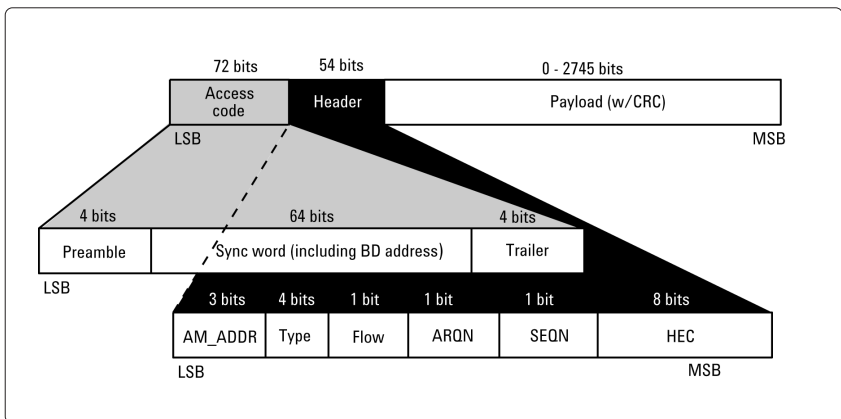

**Figure 2.** *Bluetooth* general packet format

higher-level software utilities that focus on interoperability features and functionality. The *Bluetooth* radio is the bottom layer of the protocol stack. Devices communicate among each other through the link manager. The link manager works with the link controller, which is responsible for establishing the network connections as well as power efficiency, error correction, and encryption. Figure 3 is a block diagram of a *Bluetooth* system, showing the baseband controller and the RF transmitter and receiver sections.

The *Bluetooth* Special Interest Group (SIG) has created a list, entitled “*Bluetooth RF Test Suite Structure*”, which defines tests to perform for certification of the *Bluetooth* radio layer. These tests and their required setups are described below. For specific information on test requirements, such as initial condition, test procedure, test condition, or expected outcome, refer to the *Bluetooth RF Test Specification*.

### Test Modes

A *Bluetooth* device can operate in different modes: normal mode, loopback test mode, and transmitter test mode. Normal mode consists of standard *Bluetooth* communications.

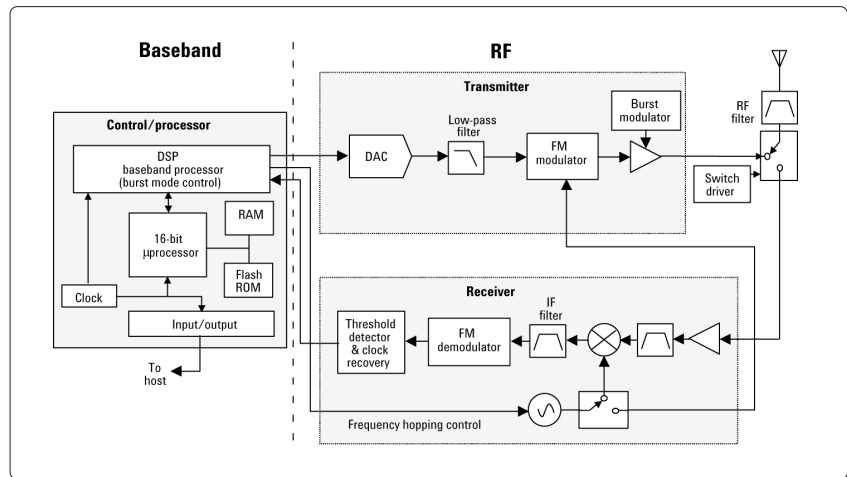

Figure 3. Block diagram of a *Bluetooth* system

In loopback test mode, the *Bluetooth* device (slave) decodes the packets sent by the tester (master) and sends back the payload using the same packet type. In transmitter test mode, the *Bluetooth* device transmits a packet according to specific instructions sent by the tester (master) via POLL packets.

The implementation of test modes in *Bluetooth* devices is required to facilitate testing of transmitter and receiver performance. When the device is in test mode, different transmission and/or reception parameters can be controlled, such as frequency selection, transmit frequency, packet type and length, bit pattern, poll period, and power level.

### Transmitter Test Setups

Different setups can be used for *Bluetooth* transmitter tests, depending on whether you are testing a fully functional *Bluetooth* device or just the RF transmitter, or even RF components of the transmitter. One way to test transmitter performance of a fully functional *Bluetooth* device is to use a special-purpose *Bluetooth* test set. The test set and DUT form a piconet with the test set acting as master and the DUT acting as slave. The test set establishes a link (paged connection) with the device in either normal or test mode using the standard *Bluetooth* protocol. With the device in test mode, the test set has complete control of DUT operation. For instance, the test set can put the device into loopback test mode or transmitter test mode, disable frequency hopping, or ask the device to transmit at specific frequencies.

Figure 4 shows this basic test setup with a test set. For the tester (master) to put the device (slave) into a test mode, the host device needs to send a special command to prepare the device to enter test mode. The control could be performed either by protocol sent over an RF connection or by direct digital control of the device (using a DUT controller).

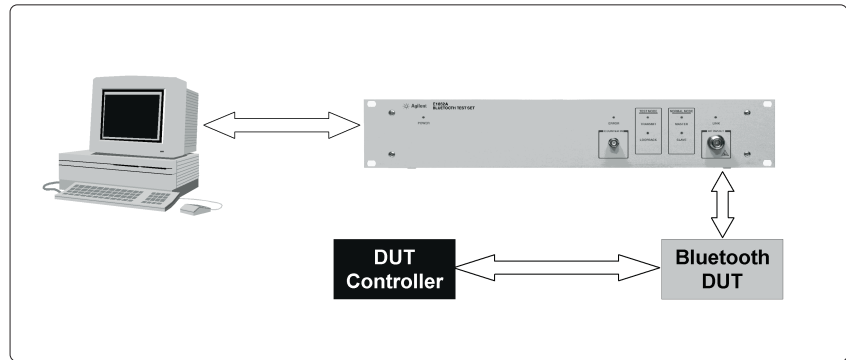

Figure 4. Example of a setup to test transmitter performance of a fully functional *Bluetooth* device. The Agilent E1852A *Bluetooth* test set is acting as a master, while the *Bluetooth* DUT is acting as a slave.

Three other types of transmitter measurement setups are shown in figure 5. Setup 1 is for testing transmitter performance of a fully functional *Bluetooth* module. Setup 2 is for testing only a *Bluetooth* transmitter, and setup 3 is for testing RF components of a transmitter. Setup 1 differs from the one in figure 4 in that there is no *Bluetooth* communication established between the device and the test equipment, so the test equipment doesn't have any control of DUT operation. For this setup, a special internal "test facilities" utility must be implemented in the device. This utility must be able to ask the device to transmit the packets it receives. This allows a *Bluetooth* signal from the digital signal generator to be transmitted into the device's receiver and looped back through its transmitter for analysis. For setup 2, the utility must have the capability to control the type of transmission

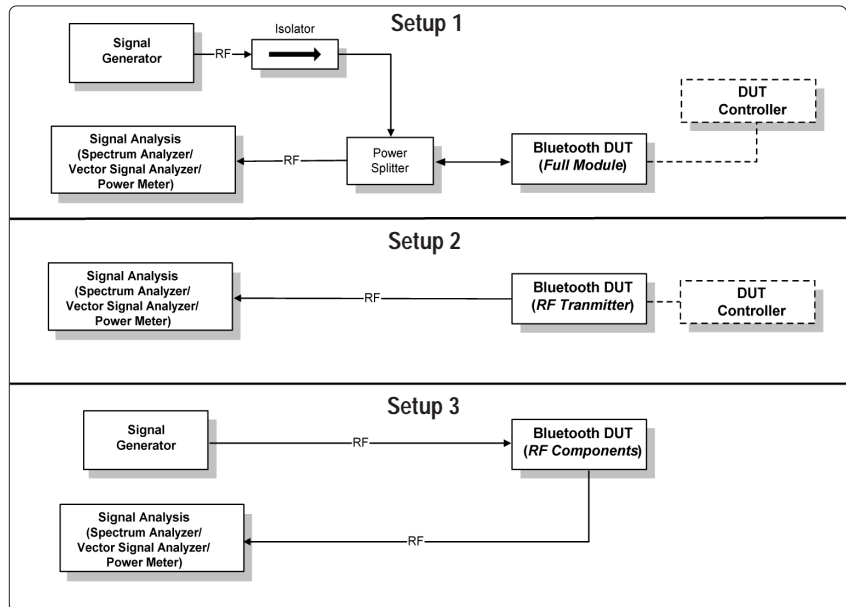

Figure 5. Examples of three other transmitter measurement setups: Setup 1) transmitter performance test setup for a fully functional *Bluetooth* device, Setup 2) setup to test performance of a complete *Bluetooth* transmitter, and Setup 3) setup to test performance of RF components of a *Bluetooth* transmitter

(frequency hopping on or off, different types of packets, and so forth) in order to provide the right conditions to test the *Bluetooth* transmitter. Setup 3 could be used to test a component such as the amplifier of a *Bluetooth* transmitter.

The frequency hopping of the *Bluetooth* system adds a further degree of complexity to signal analysis. Hopping is needed for testing the functional capability of a *Bluetooth*

device, but is not essential for parametric tests. To reduce the number of variables and identify individual performance characteristics, hopping is turned off for a number of tests. However, the transmit and receive channels can be set at the extreme ends of the band, forcing the voltage-controlled oscillator (VCO) in the DUT to switch frequency.

### Payload Data

Three different types of payload data are required for different test cases. They are PRBS9, 10101010, and 11110000. Each pattern provides different stress mechanisms and is selectively chosen for a particular measurement. PRBS9 is a pseudorandom bit sequence of period  $2^9 - 1$  that is intended to simulate live traffic and so produces a modulated signal with a spectral distribution approximating that of a real signal. The 10101010 pattern provides an additional test for the modulation filter. It also changes the spectral shape of the transmitter output. The 11110000 pattern allows a check of the Gaussian filtering. After a series of four 1s or four 0s, the output should have reached its fully settled condition. The use of different patterns also helps identify problems with IQ modulation schemes.

### Bluetooth Transmitter Tests

Transmitter tests specified for *Bluetooth* wireless technology include:

- output power
- power density
- power control
- transmit output spectrum (frequency range, -20-dB bandwidth, and adjacent channel power)
- modulation characteristics
- initial carrier frequency tolerance
- carrier frequency drift

### Power Tests

RF transmitter power measurements include output power (average peak power and maximum peak power in a burst), power density, and power control. Power level is a critical parameter in digital communication systems. These tests help to ensure that power levels are high enough to maintain links, yet low enough to minimize interference within the ISM band and to maximize battery life.

Output power measurements are performed in the time domain. Because the *Bluetooth* signal is a sequence of TDD bursts, it is necessary to trigger properly. Triggering occurs on the rising edge of the envelope to obtain a viewable signal.

Average power and peak power measurements can be performed either by a *Bluetooth* test set, a power meter, a spectrum analyzer, or a vector signal analyzer. The tester records the highest power value in the burst and calculates the average power from 20 to 80 percent of the duration of the burst. The power density measurement provides the peak power density in a 100-kHz bandwidth.

Power control tests provide testing or calibration on the level control circuitry, and are needed only for devices that support power control. Power control tests are performed in the same manner as the average power measurement, but at three discrete frequency channels (lowest, middle, and highest operating frequency).

### Transmit Output Spectrum Measurements

The transmit output spectrum measurements analyze the power levels in the frequency domain to ensure that out-of-channel emissions are minimized. This helps reduce overall system interference and ensure regulatory compliance. The *Bluetooth* specification splits the test into three parts:

- frequency range
- -20-dB bandwidth
- adjacent channel power

For the frequency-range test, the carrier is set to the upper and lower channels. A power density check is made after sampling long enough to capture the highest RF levels. The -20-dB bandwidth test is performed at the lowest, middle, and highest frequency channels, using narrower measurement filters. The adjacent channel power (ACP) test is the most complex of the three measurements. Test transmissions are made on the middle channel and 3 MHz inside the upper and lower band limits (for example, channels 3 and 75). Starting with RF channel 0, ten level measurements are made at offsets from the carrier of -450 kHz to +450 kHz. The results are summed. The measurement channel is incremented by 1 MHz and the process repeated until the top of the band is reached.

### Modulation Tests

*Bluetooth* modulation measurements consist of modulation characteristics, initial carrier frequency tolerance (ICFT), and carrier frequency drift. Modulation measurements reflect the performance of the modulator circuitry as well as the stability of the local oscillator. Both the modulator and the VCO may be affected by digital noise on the power supply or by the transmit power bursts. Verification of modulation

requires the ability to demodulate the *Bluetooth* signal so that the frequency of each bit can be determined.

The modulation characteristics test is a frequency-deviation measurement. For modulation characteristics, two sets of a repeating 8-bit sequence are used in the payload. These are 00001111 and 01010101. The combination of the two sequences checks both the modulator performance and the premodulation filtering.

Vector signal analyzers have the ability to provide comprehensive modulation quality measurements, which can detect, quantify, and help track down the sources of signal problems such as intermodulation due to transmitter interference, power supply noise modulation, and power and stability at antenna mismatch.

The initial carrier frequency tolerance test (also called frequency-offset test) verifies the accuracy of the transmitter's carrier frequency.

Carrier frequency drift consists of verification of the transmitter center frequency drift with a packet. As with the two previous tests, carrier frequency drift is measured as a demodulated signal (frequency versus time). This test is repeated with

the lowest, middle, and highest operating frequencies, first with frequency hopping off, then with it on. It is also repeated for various packet lengths. Software control can make this repetitive measurement easier.

### Transceiver Measurements

The transceiver measurements consist of performing out-of-band spurious emissions tests. These tests verify that the *Bluetooth* radio is operating within regulatory requirements. Two types of spurious emissions tests are identified in the specification: conducted emissions and radiated emissions. Conducted emissions tests measure the spurious emissions generated by the DUT from its antenna or output connector. Radiated emissions tests measure the spurious emissions leakage from the cabinet of the DUT. Spurious emissions tests can be performed using a spectrum analyzer to sweep through frequency ranges looking for spurs.

### Receiver Measurements

The receiver measurements specified for *Bluetooth* wireless technology include:

- sensitivity, single- and multi-slot packets
- carrier-to-interference (C/I) performance
- blocking performance
- intermodulation performance
- maximum input level



Bit error ratio (BER) is the criterion used to evaluate receiver performance. BER is determined by comparing transmitted and received payload data and noting the difference in bits. The BER is the ratio of the erroneous bits to the total number of bits received.

### Receiver Test Setup

Different measurement setups can be used to perform a BER measurement. As with the transmitter measurement setup, a BER measurement can be performed using a standalone *Bluetooth* test set. The setup is the same as for transmitter measurements. A link is established between the standalone tester and the *Bluetooth* DUT. The DUT, operating in loopback test mode, receives, demodulates, and decodes the incoming signal. It then repackages the recovered payload data in the same packet type as it received and retransmits the packet. The returned packet is then received by the *Bluetooth* test set, which performs a BER measurement.

A BER measurement can also be performed using a basic test system consisting of a signal generator with BER analysis capability and a signal analyzer with FM demodulation capability. This is illustrated as setup 1

of figure 6. For this setup, a special internal “Test Facilities” utility must be implemented in the device. This utility must have the ability to ask the

device to retransmit the packets it receives. This allows a *Bluetooth* signal from the digital signal generator to be

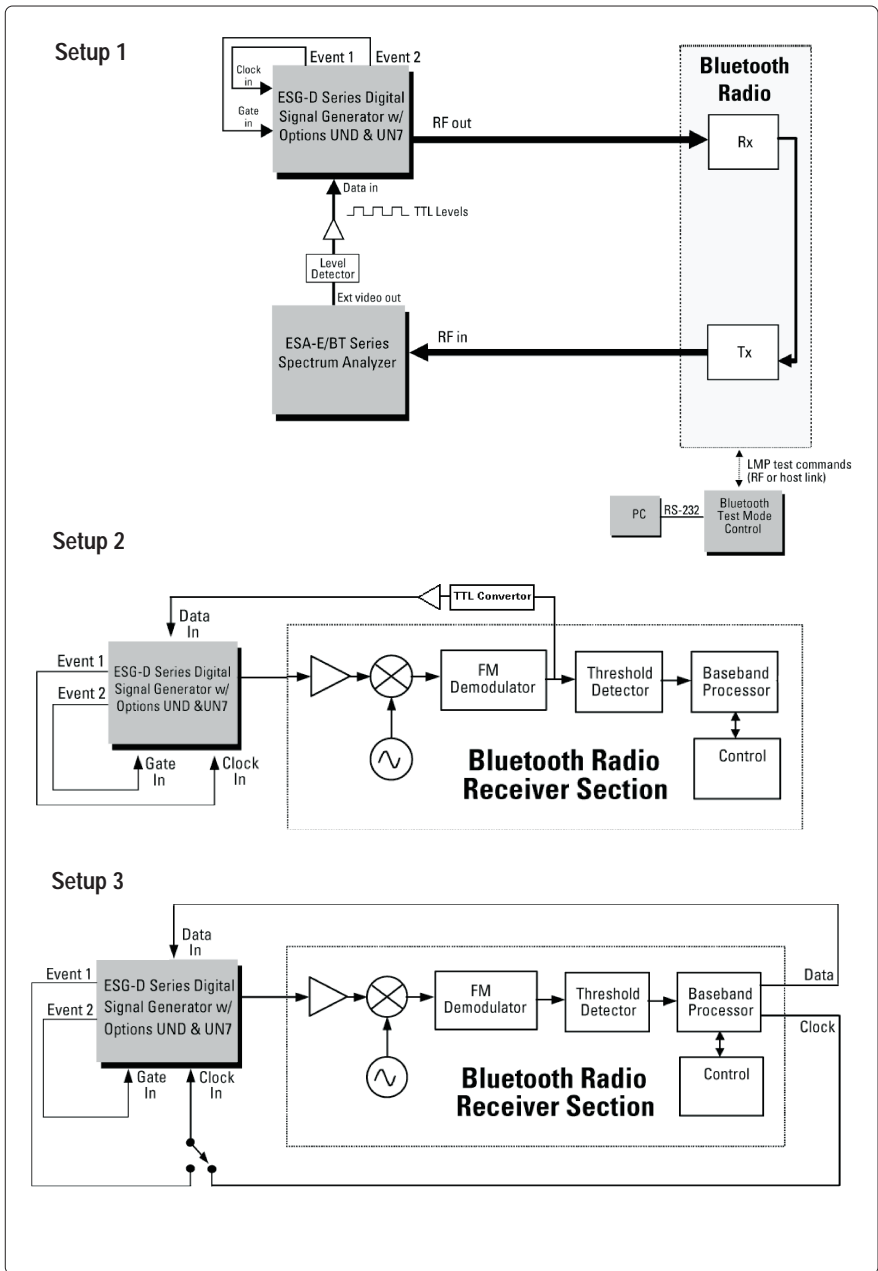

Figure 6. Examples of three other receiver measurement setups: Setup 1) BER measurement setup using a signal generator and spectrum analyzer, Setup 2) BER measurement setup using the demodulated *Bluetooth* signal at the discriminator output, and Setup 3) BER measurement setup using the *Bluetooth* baseband signal at the baseband processor output

received, demodulated by the device's receiver, looped back through its transmitter, and sent back to the spectrum analyzer. The signal is then demodulated by the spectrum analyzer and re-sent to the signal generator to perform the BER measurement.

In both of the first two measurement setups, the *Bluetooth* device must have the ability to retransmit the recovered data from the received signal. It must support loopback test mode or have a "loopback test facility" internally implemented.

Setups 2 and 3 of figure 6 are examples of BER measurement setups in which the *Bluetooth* DUT is simply acting as a standard receiver. No loopback is performed between its receiver and transmitter. The BER measurement is performed using a signal generator with an internal BER analyzer.

In setup 2, the DUT receives and demodulates the signal from the signal generator, providing access at the FM

discriminator output. The demodulated packets are then fed to the data input of the signal generator's BER analyzer. A TTL converter is required for signal conditioning between the FM discriminator output and the BER analyzer input.

In setup 3, the DUT receives and demodulates the signal, then provides access to the *Bluetooth* baseband signal at the baseband processor. As with setup 2, the *Bluetooth* packets at the output of the baseband processor are fed to the data input of the signal generator's internal BER analyzer.

When the *Bluetooth* DUT does not support loopback test mode, Packet Error Rate (PER) measurements can be made instead of BER ones. This measurement can be made using a *Bluetooth* test set operating in transmitter test mode or normal mode. Although the PER measurement is not part of the *Bluetooth RF Test Specification*, it still provides insight into the performance of a *Bluetooth* receiver.

## Receiver Sensitivity

*Bluetooth* receiver sensitivity is a measure of the minimum signal level required by the receiver to produce a maximum-allowed BER. Sensitivity is tested by sending a *Bluetooth* signal with various impairments to the receiver and measuring the BER of the recovered payload data. To meet the *Bluetooth* requirement, the receiver's BER must not exceed 0.1 percent when the transmit power is such that the signal level at the receiver input is -70 dBm. (This is referred to as the reference sensitivity level.) The test is performed at the lowest, middle, and highest operating frequencies of the DUT, and also for single- and multi-slot packets.

## Carrier-to-Interference (C/I) Performance

C/I performance is measured by sending co-channel or adjacent-channel *Bluetooth* signals in parallel with the desired signal and then measuring the receiver's BER. The test is performed at the lowest, middle, and highest operating frequencies of the receiver, with the interfering



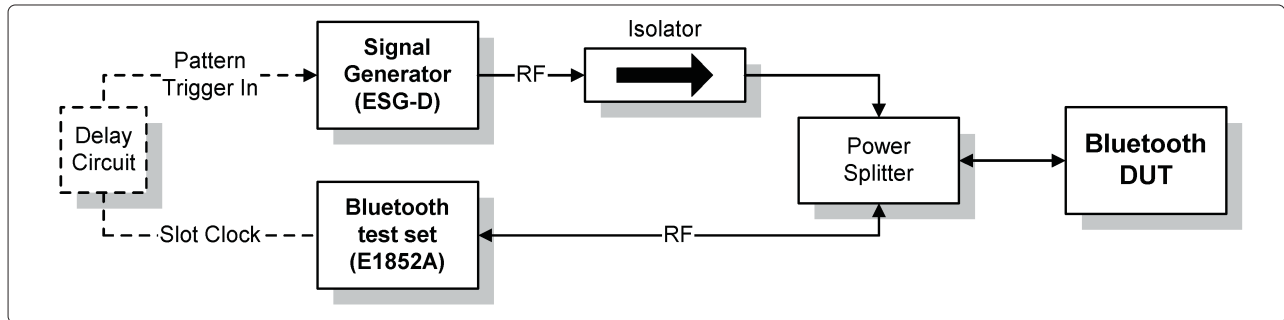

Figure 7. Test setup to perform the carrier-to-interference (C/I) performance test

signal at all operating frequencies within the band. Figure 7 shows an example of a setup that could be used to perform this test. The *Bluetooth* test set establishes communication with the DUT and provides the wanted signal, while the digital signal generator produces a *Bluetooth* modulated interfering signal. The returned packets from the DUT are received by the *Bluetooth* test set, which measures the BER.

### Blocking Performance

The receiver blocking performance is measured by sending a continuous wave (CW) interfering signal with the desired signal and then measuring the receiver's BER. This measurement can be performed with a setup like the one in figure 7, only with an analog rather than a digital signal generator.

### Intermodulation Performance

Intermodulation performance measures unwanted frequency components resulting from the

interaction of two or more signals passing through a nonlinear device. The desired signal is transmitted along with a static sine wave and another *Bluetooth* modulated signal. The test setup in figure 7 can be reused for this test by adding an extra interference source to provide the static sine wave signal.

### Maximum Input Level

The maximum input level test measures the receiver's BER performance when the input signal is at the specified maximum power level (-20 dBm). This test is also performed at the lowest, middle, and highest operating frequencies.

### Power Supply Measurements

Power supply testing, and the *Bluetooth* device's rejection of spurious signals carried on the power line, are important parts of integration testing for many applications. Measurements of

power versus time during multi-slot packet bursts and careful monitoring of the frequency error measurements are good ways to uncover power-line-related problems.

To get the time-to-market advantage for the vast potential of *Bluetooth* products, you need to have test capability ready when your *Bluetooth* designs are ready for testing. Many test setups are possible to get the job done, using a variety of equipment and providing different ease-of-use levels. The Agilent Technologies application note 1333-1, *Bluetooth RF Measurement Fundamentals*, contains further explanations of the tests required for *Bluetooth*™ radio layer certification, and the equipment needed to accomplish this. Find this application note and further *Bluetooth* information online at [www.agilent.com/find/bluetooth](http://www.agilent.com/find/bluetooth).

Visit Agilent's library of application notes,  
training courses, FAQs, tutorials, and more at  
[www.agilent.com/find/test](http://www.agilent.com/find/test)

By internet, phone, or fax, get assistance  
with all your test & measurement needs

Online assistance:  
[www.agilent.com/find/assist](http://www.agilent.com/find/assist)

*Bluetooth™* and the *Bluetooth™* logos are  
trademarks owned by *Bluetooth™* SIG, Inc.,  
and licensed to Agilent Technologies, Inc.

Expanded from original article in Agilent  
Measurement Solutions Volume 1. Issue 1

© Agilent Technologies, Inc. 2001  
Printed in USA November 1, 2001  
5988-4706EN



**Agilent Technologies**