

Agilent Antenna and RCS Measurement Configurations Using PNA Microwave Network Analyzers

White Paper

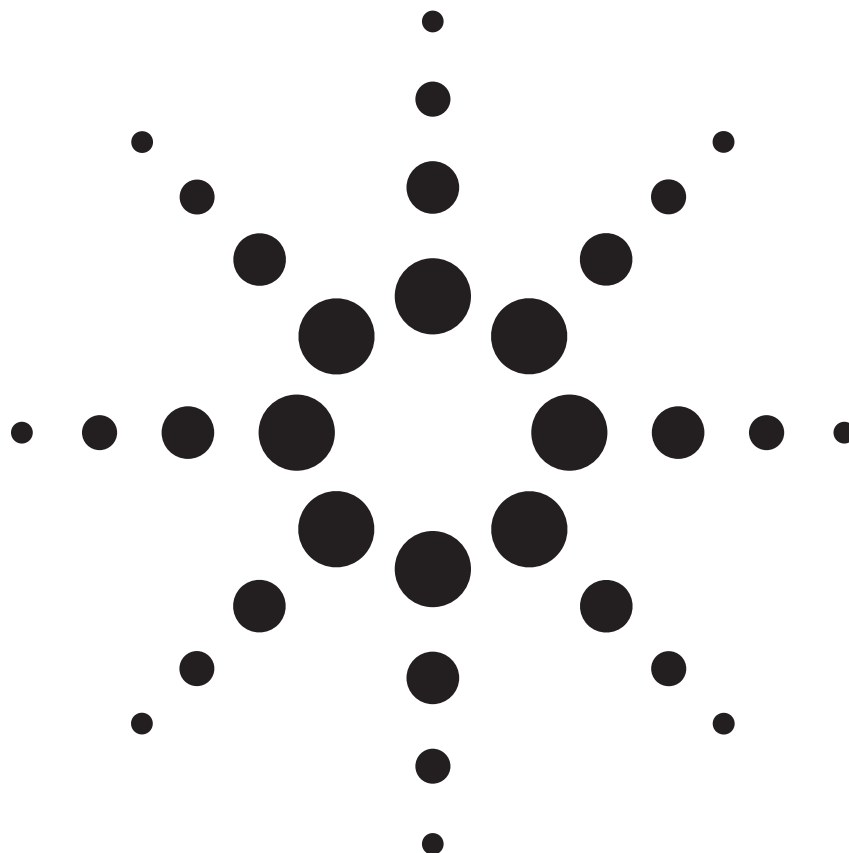

Agilent Technologies

Abstract

As technology changes, new and different techniques for measuring and characterizing antenna performance need to be considered. This paper examines how a new generation of network analyzers can be utilized in antenna measurement configurations to make fast, accurate, and reliable measurements. The paper will list and explain the features of Agilent's new PNA series of network analyzers that are particularly well suited for antenna and Radar Cross-Section (RCS) measurements. The new PNA series network analyzers are compared to the 8530A microwave receiver to differentiate and contrast the two instruments in antenna/RCS configurations. The primary information in this paper will be the configuration diagrams for the PNA in a variety of antenna test configurations such as near-field, far-field, radar cross-section, and compact ranges. Important technical information that needs to be considered for each of the antenna test configurations utilizing a PNA will also be discussed. Typical performance specifications of the PNA and measurement system when used in an antenna/RCS configuration will also be presented. A summary of the advantages and disadvantages of the new performance network analyzers are presented to allow antenna test professionals to evaluate this new product for their antenna test configurations.

Keywords: Antenna, radar cross section, measurement, RCS, instrumentation, test equipment, configurations, speed, time.

Introduction

Antenna measurements have been evolving for many years, and they will continue to evolve in the future. When we choose to operate in a high technology industry, we have to accept the fact that we will need to change with advances in technology. New technologies bring better, faster, more accurate measurement capabilities. To remain competitive in this industry, we need to evolve and change with technology, or get left behind. Prior to the 1980s, antenna test engineers were using dedicated microwave receivers for antenna test applications. In 1985 some companies began using a network analyzer as a receiver for antenna test applications [1,2]. New technology had brought greater stability, accuracy, repeatability, and reliability to instrumentation, and the early adopters of this new technology applied it to antenna and RCS measurements [3]. Using a network analyzer as an antenna receiver was a new and novel idea in 1985. The companies and individuals who adopted using the network analyzer technology to make antenna/RCS measurements were leading innovators [4], and many others came to follow this technology lead in later years. Over the years, with many antenna test facilities adopting this new superior technology, the network analyzer evolved into a dedicated microwave receiver specifically for antenna/RCS measurements [5].

With the next generation of network analyzers now available to the industry, history shows that the antenna test community needs to evaluate this new technology to see if it can provide similar gains in improved performance, accuracy, and speed, to provide a better value for the antenna test community.

This paper examines how Agilent's new PNA series of network analyzers can be utilized in various antenna and RCS measurement applications. The technical considerations, advantages, and tradeoffs of using these new network analyzers in antenna/RCS applications will be discussed in this paper.

Introducing a New Series of Network Analyzers

Agilent introduced the E836xB and E8361A PNA series of microwave network analyzers in October 2002. The new family consists of 4 different network analyzers each with different broadband frequency ranges [6]. They range from a low frequency of 10 MHz to either 20, 40, 50, or 67 GHz. The analyzers feature an integrated microwave source and receiver in the same instrument. All of the new network analyzers in the PNA family have similar features, and incorporate the latest designs, components, and technologies to provide highly reliable operation. Additionally they incorporate new technologies and features to provide better performance and capabilities to antenna/RCS test applications.

It is useful to examine the performance features of the new PNA family that are specific to antenna/RCS applications. Since there is a measurement speed versus measurement sensitivity tradeoff dependent upon receiver bandwidth, all measurement times and sensitivities are referenced to a 10 kHz IF bandwidth unless otherwise stated to facilitate easy comparisons to the 8530A microwave receiver. The sensitivity achieved when the PNA is operated in a remote mixer mode is -114 dBm, which is the same as the popular 85301B system. When compared to the popular 8530A/8511 and 8720 systems, the sensitivity achieved by the new PNAs is 16-24 dB better. The dynamic range of the PNA series is the same as the 85301B system. Measurement speed or data acquisition time is 24 μ S (40 kHz IF bandwidth), and 119 μ S (10 kHz IF BW), which is significantly faster than the 200 μ S data acquisition time of the 8530A. On far-field ranges, where remote sources are used, the PNA has a frequency agility of 4-6 mS,¹ which is 25-33% faster than the 6-8 mS achieved with the 85301B system. Compression levels, mixer match, and isolation of the PNA series are the same as for the 85301B system. Extremely fast data transfer rates out of the network analyzers are accomplished using the COM/DCOM features, and provide data transfer rates that are hundreds of times faster than the 8530A. A new feature unique to the PNA family is the ability to select from 29 different IF bandwidths, allowing the user to optimize the sensitivity versus measurement speed tradeoff to fit the particular measurement and application requirements.

There are additional new features that can prove useful to antenna/RCS applications. Up to four simultaneous test receivers (A, B, R1, R2) are available in the standard PNA, providing three test channels. With option 080, a fifth internal receiver is added, which is used for phase lock, providing up to four test receivers for multiple-channel measurements. The 10 MHz to 67 GHz PNA provides the widest frequency range of operation available in a single instrument. If you do not require the higher frequencies of operation, other analyzers in the PNA family have a less broad frequency range, and save money. As with all network analyzers utilized in antenna/RCS operations, this single asset can be utilized as both a network analyzer or microwave receiver, doubling the utility of your capital investment. There are 16,001 data points available for each trace, providing extremely long alias-free RCS down-range resolution. When you combine the high data point storage capability with the fast data transfer capabilities, extremely data intensive measurements are no longer a problem. For secure environments, the PNA family features a removable hard drive to completely ensure the security of the data that is acquired by the PNA. There are many more new features in the new PNA family of network analyzers. From LAN connectivity through a built-in 10/100 Mb/s LAN interface, to all the features associated with a modern Windows 2000® operating system.

1. For a 10 kHz IF bandwidth on the PNA; for very narrow PNA IF bandwidths, this number increases.

Near-field Antenna Measurements

A near-field antenna measurement configuration utilizing a PNA network analyzer is shown in Figure 1. This configuration is similar to a near-field measurement system which utilizes an 8720 network analyzer. However, the new PNA analyzer has several new features and performance capabilities that make it even better suited for near-field antenna measurements. The new PNA analyzer has a user selectable variable IF bandwidth. Because the n-f probe is located very close to the AUT, sensitivity and dynamic range are not as important a performance consideration as in a far-field antenna range. The user selectable bandwidth feature can be utilized to optimize the measurement speed vs. sensitivity tradeoff. By selecting the widest bandwidth available (40 kHz), the measurement speed is maximized. The PNA provides a data acquisition rate of 24 uS (40 kHz IF BW), and 119 uS (at 10 kHz IF BW) versus 310 uS for the 8720 (at 6 kHz BW), which is a significant reduction in data acquisition time. Since the new PNA analyzer is mixer based, with fundamental mixing to 20 GHz, instead of sampler based as in the 8720, there is a 24 dB increase in sensitivity and dynamic range in the new PNA over the 8720. This increased sensitivity and dynamic range more than makes up for the reduction realized when the IF bandwidth of the PNA is opened up to its maximum to maximize measurement speed. So the new PNA can achieve faster data acquisition speeds with increased sensitivity in near-field applications.

Fast frequency agility is important when making multiple-frequency near-field measurements. For an example of the typical frequency agility for the PNA, consider the PNA stepping through 8, 9, 10, 11, and 12 GHz in a near-field measurement. The PNA can step through these five frequency points in 21.2 mS, or approximately 4.25 mS per frequency point. As a comparison, the 8720 would take 450 mS, or 90 mS per point to step through these same frequency points. Thus the PNA's frequency agility time is 21 times faster than the 8720.

One current limitation of the PNA for near-field antenna measurements, which is the same as for the 8720, is the network analyzers inability to perform a reverse frequency sweep. Because of this, near-field probe scans would need to be performed in the same direction, requiring a retrace of the probe to its starting position without taking data.

For basic near-field measurements that are not data intensive, there will be little noticeable difference in total measurement times between the PNA and an 8720 or 85301B/C system, because of limitations on probe velocity. When there is a data intensive acquisition, such as with active array antennas, then the faster data acquisition times, and frequency agility of the PNA, will make a noticeable difference in overall measurement times.

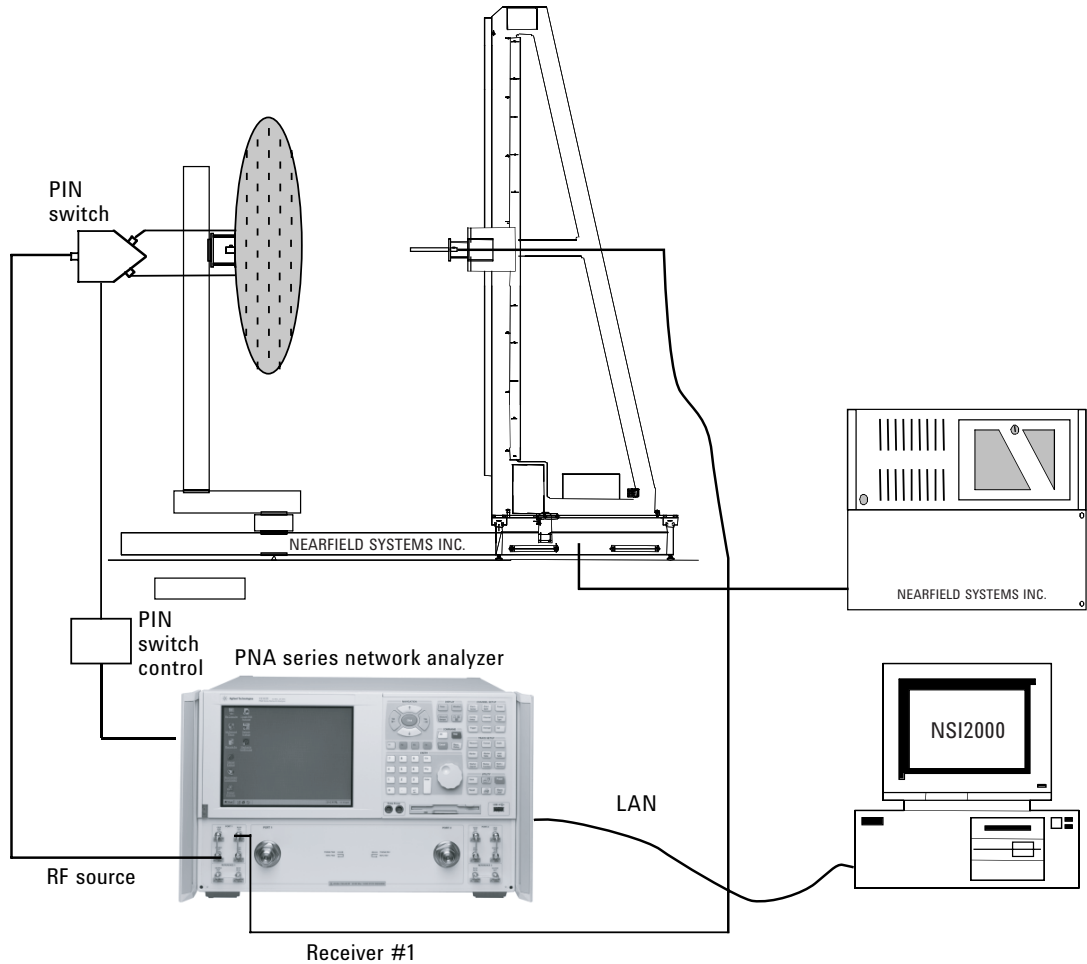

Figure 1. Typical near-field antenna measurement configuration using a PNA with Option 014.

Radar Cross-Section Measurements

For Radar Cross-Section measurements (RCS), the primary concerns for the measurement instrumentation are sensitivity, frequency agility, and data acquisition times. The PNA family of network analyzers is ideally suited for RCS applications. Many RCS ranges have utilized either the 8530A/8511 or the 8720 for the microwave RCS receiver. These receivers were chosen for their ability to provide fast frequency sweeps with good sensitivity. The harmonic sampling downconversion technology utilized in these receivers provided the fast sweep frequency agility desired for RCS applications, but had a tradeoff of not as much sensitivity as a fundamental or low-harmonic external mixing downconversion technology. The 85301B system which utilized external mixers had the advantage of the superior sensitivity that was desired for RCS measurement applications, but had a tradeoff of requiring a relatively slower STEP frequency sweep (instead of a RAMP sweep utilized in the 8530A/8511 system) and the associated slower STEP frequency agility speeds of 6-8 mS. While both the harmonic sampling and external mixing systems were widely used in RCS applications, test engineers had to choose between a receiver downconversion technology that was either optimized for measurement sensitivity or frequency agility.

The new family of PNA network analyzers makes a significant contribution to RCS measurements, providing both excellent measurement sensitivity and fast frequency agility. The PNAs utilize mixer based downconversion technology to provide excellent measurement sensitivity, and with the source and receiver located in the same instrument, can provide very fast frequency agility speeds of 119 μS^1 per frequency point. Thus the new PNAs provide both the sensitivity, frequency agility, and fast data acquisitions speeds required by RCS ranges in one new instrument.

The frequency agility speeds for the PNA are also significantly faster than previous receivers. To get an appreciation of the reduced data acquisition times that can be achieved with a PNA, it is useful to compare the measurement times of an 8530A versus a PNA based system in a typical RCS down-range measurement acquisition. For comparison purposes, let's choose an 8-12 GHz, 801-point frequency sweep, (10 kHz IF BW). For the 85301B system (8530A with external mixers) it would require 4.8 seconds to complete a STEP sweep. The 85301C (8530A/8511 harmonic sampler downconversion) would require approximately 184 mS^2 for a RAMP sweep. The PNA would be significantly faster, taking only 300 mS to complete a STEP sweep, and 124 mS to complete the RAMP sweep. Thus for a single down-range frequency sweep acquisition, the PNA would be 16 times faster in STEP mode, and 1.5 times faster in RAMP mode than the 8530A. Considering that a full RCS data acquisition requires acquiring cross-range data that consists of many (perhaps a 100 or more) down-range acquisition sets of data, we see that the PNA can reduce the total data acquisition times on an RCS range significantly. Since the frequency agility and data acquisition times are dependent upon sweep bandwidth, number of frequency points, and IF bandwidth of the receiver, consult the PNA data sheet [7] for specific measurement times for your RCS application.

1. Bandcrosses add 2-3 mS, and retrace is ~11 mS
2. 230 μS per data point + 100 mS per bandcross of the 836xxB source.

The PNA has excellent measurement sensitivity, and fast data acquisition speeds, both of which are very important for RCS applications. With the new PNA, the RCS professional no longer has to choose between a receiver either optimized for sensitivity or one optimized for measurement speeds since the PNA has both excellent measurement sensitivity, and faster measurement speeds. The new PNA has 29 user selectable IF bandwidths, ranging from 1 Hz to 40 KHz. This allows the engineer to optimize the bandwidth and measurement speed tradeoff to meet the particular test requirement. This selectable bandwidth feature will prove useful in RCS applications.

Figure 2 shows a typical RCS measurement configuration utilizing a PNA analyzer. Notice that two of the receivers are utilized for simultaneous measurement of the co- and cross-polarized response. The PNA has the ability to write a digital word to the AUX output connector, and this digital word could be utilized to control a PIN switch for controlling the transmit polarization. Not shown in this example configuration is a pulse hardware gating module, which could easily be added to a PNA RCS configuration for those applications requiring pulse hardware gating.

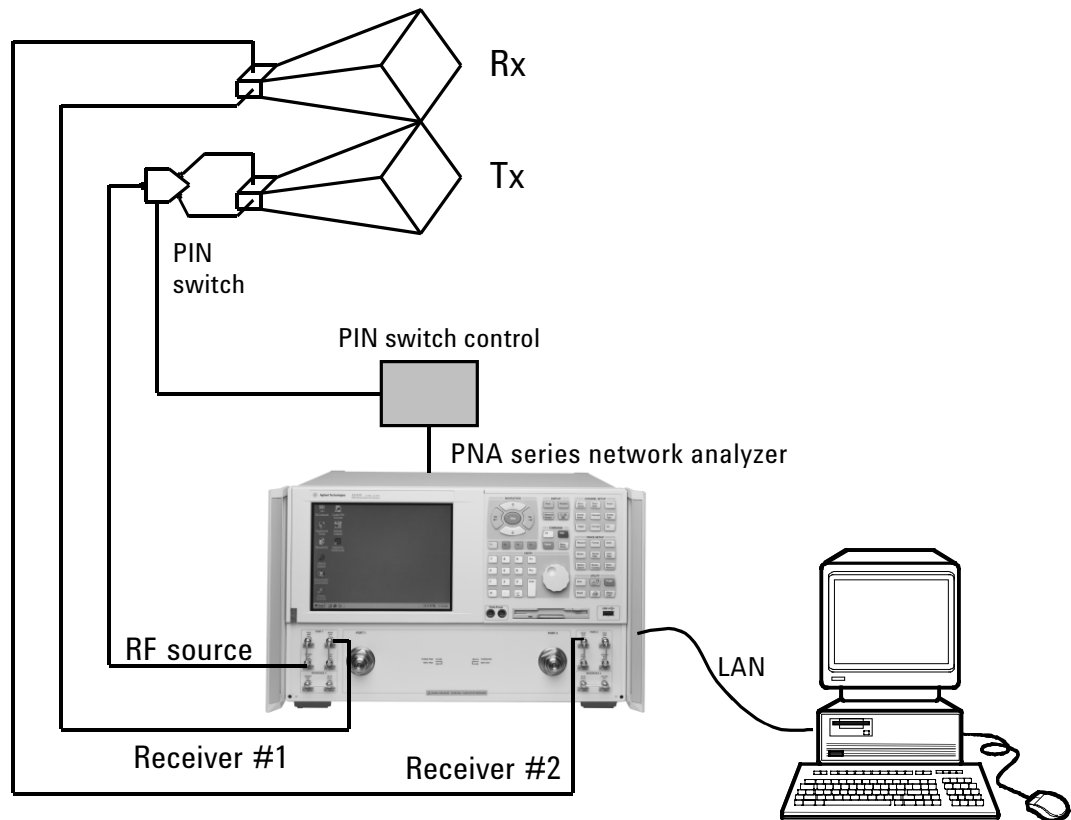

Figure 2. Typical RCS measurement configuration using a PNA with Option 014.

There are several additional features of the PNA that are particularly useful in RCS configurations. Up to 16,001 data points are available per measurement trace, which provides extremely long alias-free down-range resolution for RCS measurements; the 8530A has a maximum of 801 data points. Having the source and receiver integrated into the same instrument, and having several different PNAs with different frequency ranges to select from has proven to be very cost effective in RCS applications. And since RCS measurements often have data security requirements, the removable hard drive meets these needs.

Far-field Antenna Measurement Configurations

For far-field antenna measurements, the PNA based system is very similar to the popular 85301B external mixer based system. Figure 3 illustrates a typical far-field antenna measurement configuration. The PNA based system utilizes the same 85320A/B broadband external mixers, as well as the R, Q, U, V, and W-band 85325A millimeter wave mixers, and the same 85309A distributed frequency converter. The internal microwave synthesized source of the PNA is utilized as the LO source for the 85309A, saving the cost of an external LO source. With option H11 on the PNA, the external downconversion by the 85309A is to an IF frequency of 8.333 MHz (instead of 20 MHz). This 8.333 MHz IF signal bypasses the first downconversion stage in the PNA, and is routed directly to the input of the second downconversion stage in the PNA. This reduces the system noise figure from approximately 36 dB to less than 20 dB, and allows achieving the excellent measurement sensitivity of -114 dBm, which is a 16-24 dB improvement in measurement sensitivity over the 8511 and 8720 receivers, which is very significant in RCS applications. Option H11 on the PNA provides the external connectors to route the external IF input directly to the second downconversion stage of the PNA via the rear panel.

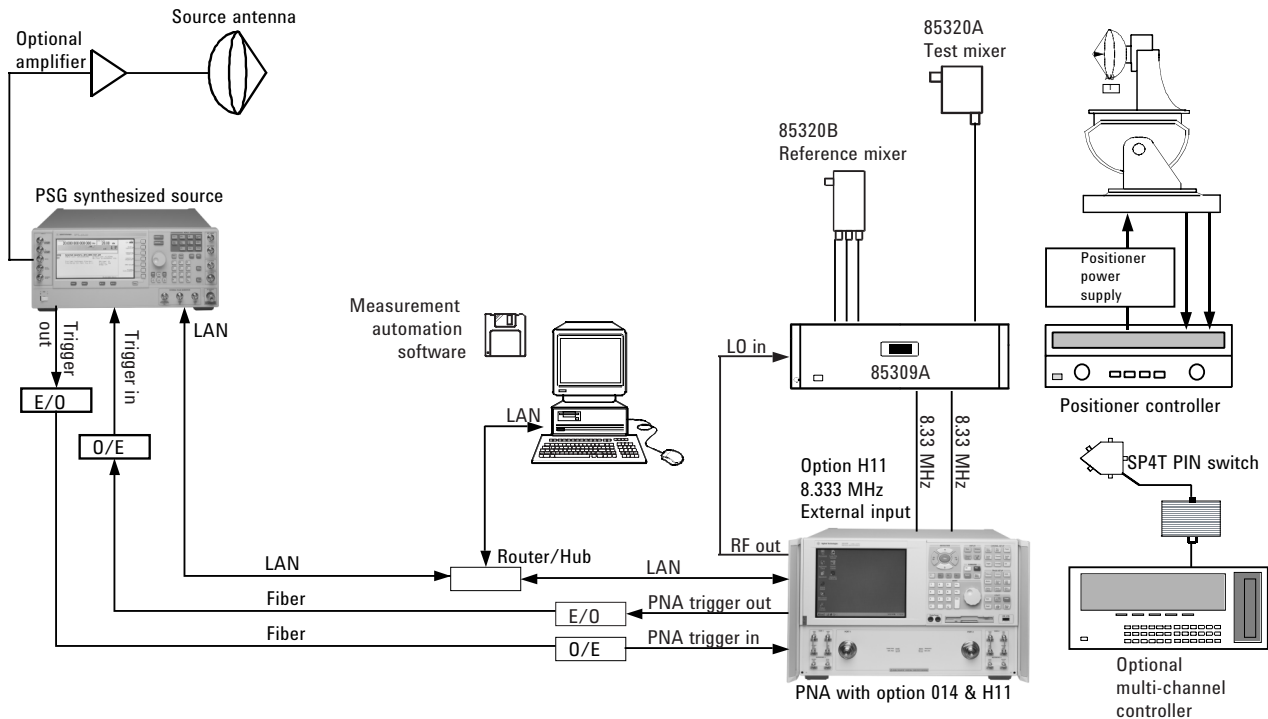

Figure 3. Typical far-field antenna measurement configuration.

One of the key benefits of a PNA being utilized on a far-field antenna range is the significantly faster data acquisition times available from the PNA. With the PNA bandwidth set to 10 kHz (the same as the 8530A), the data acquisition time is 119 μ S, as compared to a 230 μ sec data acquisition time for the 8530A. Thus the PNA's data acquisition speed is 1.93 times faster than the 8530A. Because of limited positioner rotation speeds, this faster data acquisition speed may not be useful in far-field applications unless the data acquisition is quite intensive as would be the case with active array antennas. However, with faster data acquisition speeds, the IF bandwidth could be narrowed, improving measurement sensitivity (which is very important on a far-field range), without increasing total measurement times.

Frequency agility of the PNA operated in a far-field antenna configuration is 4-6 mS^1 , as compared to a 6-8 mS frequency agility for the 85301B system. This results in a 25-33% reduction in the frequency switching time for the far-field measurement system. For multiple-channel, multiple-frequency applications with the PNA, one can use the 85330A multiple-channel controller, the same as for the 85301B configuration [8].

A key requirement for this far-field configuration is transmitting the 'PNA trigger out,' and 'PNA trigger in,' across the far-field range to the remote PSG source. A possible solution as shown in Figure 3 is to use fiber optic transceivers. Other common variations to the far-field configuration, such as adding a multiple-channel controller to provide multiple channel, multiple-frequency measurements is possible.

Other Test Range Configurations

There are many different variations on the basic antenna/RCS ranges, and not all configurations and variations can be discussed in this limited space. The examples provide typical configurations and measurement times, to guide the antenna test professional in designing their own measurement systems. The actual measurement times and performance will vary with different antenna or RCS configurations.

1. For a 10 kHz IF bandwidth on the PNA; for very narrow PNA IF bandwidths, this number increases.

Typical Performance Comparisons

The performance of the new PNA receivers when utilized in an antenna/RCS measurement system is summarized in table 1. As can be seen from the performance comparisons, the PNA compares very favorably to the popular 85301B/C antenna measurement systems. Their measurement sensitivity, which is a significant factor in measurement accuracy, is identical, ensuring the PNAs provide the same excellent measurement accuracy as does the 85301B system. Comparing the specifications that affect measurement times, it can clearly be seen that both the data acquisition times and frequency agility speeds of the new PNAs are significantly faster than the 85301B/C antenna measurement system. With these faster data acquisition speeds, the total test time required to complete a measurement will be reduced, providing a significant economic benefit to antenna range operators.

Summary

A new network analyzer that can be utilized in antenna/RCS measurement configurations was presented. New and unique features that are particularly well suited to antenna/RCS applications were presented, and compared and contrasted to other measurement receivers. Typical configurations diagrams for the PNA in a variety of antenna/RCS test applications, as well as example measurement scenarios and associated measurement times were presented to guide antenna test professionals in designing their own measurement systems to meet their unique requirements. Typical performance specifications as well as advantages and tradeoffs of the new PNA were also presented.

Conclusions

It was shown that this new network analyzer would provide significant performance enhancements to antenna/RCS measurements. One of the key economic benefits of this new network analyzer is the faster data acquisition speeds that will reduce total measurement times, while still retaining full network analyzer capabilities.

Table 1: Typical performance comparison for antenna/RCS measurement systems.

Receiver/ network analyzer	PNA	PNA	85301B	85301C	8720ES-012
Downconversion	Option 014 ¹	Remote Mixers	Remote mixers	Harmonic sampler	Harmonic sampler
Bandwidth and averaging	10 kHz, 1 avg.	10 kHz, 1 avg.	10 kHz, 1 avg.	10 kHz, 1 avg.	6 kHz, 1 avg.
Sensitivity (dBm)	-104	-114	-113	-98	-90 ²
Dynamic Range (dB)	94	90	89	88	85
Compression level (dBm)	-10	-24	-24	-10	-5
Data acquisition time:					
CW mode (uS)	119	119	230	230	310
RAMP sweep (uS)	119 ³	119 ³	N.A.	230 ⁴	310 ⁴
STEP sweep (uS/mS)	<400 uS	<400 uS	6-8 mS	N.A.	90 mS
With far-field remote source	4-6 mS	4-6 mS	6-8 mS	6-8 mS	N. A.

1. Option 014 - direct access to mixers via front panel; the configuration used in the near-field and RCS examples.

2. 8720ES with Option 012 from 0.050-20 GHz; -83 dBm sensitivity 20-40 GHz.

3. Bandcrosses add typically 2-3 mS; retrace time is typically 11 mS.

4. Typical times without a bandcross; bandcrosses add typically 100 mS.

References

- [1] John W. Boyles, "Long Range Antenna Measurements with the HP 8510 Using Harmonic Mixers," 1986 AMTA proceedings.
- [2] John W. Boyles, "Selecting a Mixer for Antenna Test Applications," 1987 AMTA proceedings.
- [3] R. Balaberta, and Shatnu R. Mishra, "On the use of the HP 8510 Network Analyzer for Antenna Pattern Measurements," 1986 AMTA proceedings.
- [4] Dan Slater, and Greg Hindman, Nearfield Systems, Inc. "A Low-cost, Portable Near-field Antenna Measurement System," 1989 AMTA proceedings.
- [5] John Swanstrom and Robert Shoulders, "Pulsed Antenna Measurements with the Agilent 8530A Microwave Receiver," 1994 AMTA proceedings.
- [6] "PNA Series RF and Microwave Network Analyzer," brochure, literature number 5968-8472EN, September 25, 2002
- [7] "Agilent PNA Series Microwave Network Analyzers," data sheet, literature number 5988-7988EN, April 16, 2003
- [8] "85330A Multiple Channel Controller," data sheet, literature number 85330-90019, October 2002
- [9] "85301B/C Antenna Measurement System," configuration guide, literature number 5967-6042E, September 1999.
- [10] "Antenna Test Solutions Catalog," literature number 5968-6759E, October 1999.
- [11] "Agilent 8720E Family Microwave Vector Network Analyzer," data sheet, literature number 5968-5163E, February 12, 2001.
- [12] "Triggering the PNA Series Network Analyzer for Antenna Measurements," white paper, literature number 5988-9518EN, May 28, 2003.
- [13] "Pulsed Measurements Using The Microwave PNA Series Network Analyzer," white paper, literature number 5988-9480EN, May 22, 2003.

Content herein was presented at the 2003 Antenna Measurement Techniques Association. John Swanstrom, Jim Puri, Bill Kwan, and Keith Anderson, "Antenna and RCS Measurement Configurations Using Agilent's New PNA Network Analyzers" AMTA Proceedings, pp 573-579.

Web Resources

For additional PNA Series product information visit our web site:

www.agilent.com/find/pna



Agilent Email Updates

www.agilent.com/find/emailupdates

Get the latest information on the products and applications you select.

Agilent T&M Software and Connectivity

Agilent's Test and Measurement software and connectivity products, solutions and developer network allows you to take time out of connecting your instruments to your computer with tools based on PC standards, so you can focus on your tasks, not on your connections. Visit www.agilent.com/find/connectivity for more information.

By internet, phone, or fax, get assistance with all your test & measurement needs

Online Assistance:

www.agilent.com/find/assist

Product specifications and descriptions in this document subject to change without notice.

Windows 2000® is a U.S. registered trademark of Microsoft Corporation.

© Agilent Technologies, Inc. 2003, 2004
Printed in USA January 28, 2004
5989-0220EN



Agilent Technologies