

Agilent N9355/6 Power Limiters

Application Note

Protect your investments with
Agilent power limiters

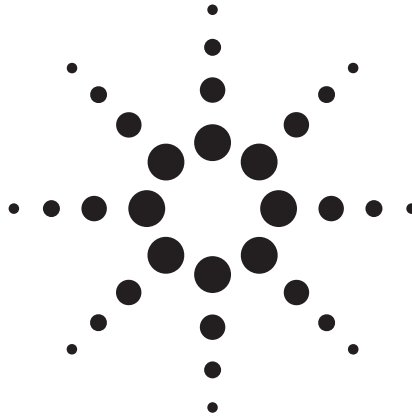

Agilent Technologies

Abstract

Many receivers are often at risk of having their front ends burned out by high power RF and microwave stray signals. The same applies for sensitive microwave components such as detectors, mixers and amplifiers. These instruments and devices are also easily damaged by electrostatic discharge (ESD). This paper outlines application considerations and the latest limiter technologies available from Agilent Technologies.

Introduction

Microwave and RF receivers, as well as many instruments and components are susceptible to damage from high power CW and pulsed microwave signals, with amplitudes exceeding certain danger levels. For some instruments, this danger level may be as low as one watt (+30 dBm).

These types of sensitive instruments and components are traditionally protected by a power limiter. The limiter should have the following characteristics for maximum protection:

- Provide very low insertion loss to signals with amplitude below the limiting threshold
- Offer very high loss to signals which exceed the limiting threshold
- Possess very fast response time, providing protection within nanoseconds of the arrival of a damaging signal

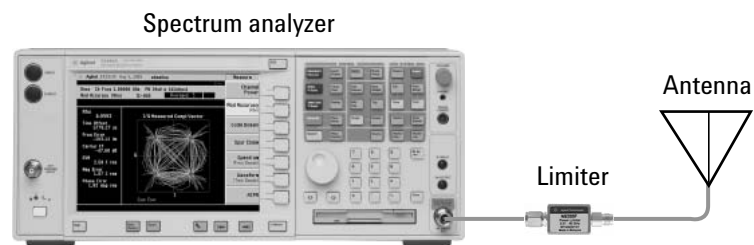

Figure 1. Typical application of power limiters

Limiter Basics

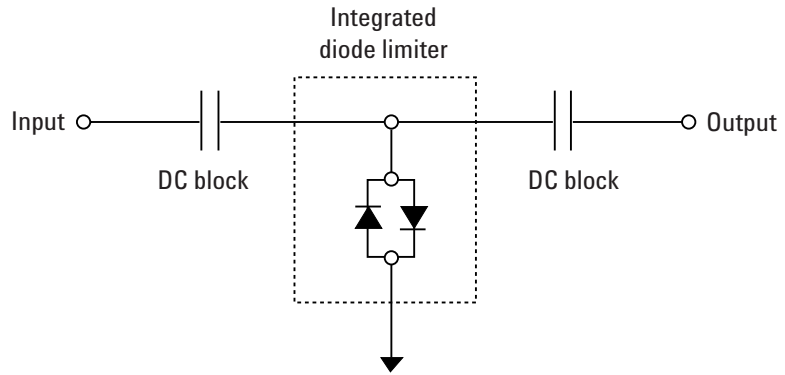

Figure 2. Block diagram for N9355 and N9356

The Agilent N9355/6 series of limiters consists of DC blocking capacitors at both input and output ports, and an integrated diode limiter circuit. The integrated circuit contains either Planar-Doped-Barrier (PDB) or Schottky diodes mounted in shunt across a 50 ohm transmission line.

For incoming signals which are below the limiting threshold in amplitude, the signal passes with relatively low power loss. Insertion loss and return loss (VSWR) are defined in this region. As the incident signal exceeds the limiting threshold power level, the RF power causes the integrated diode in the limiter to self-bias. This decreases the forward resistance of the diodes, and results in the incident signal being attenuated. The limiting threshold (or 1 dB compression point) is defined as the incident power level at which the output power level is attenuated by 1 dB, excluding transmission line losses.

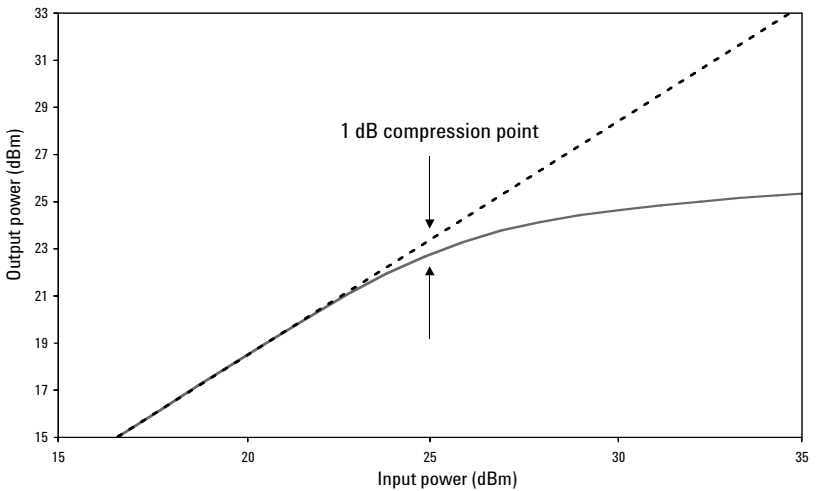

Figure 3. Typical limiting curve for N9356B

As the incident power level increases, the attenuation level also increases until the diodes reach their saturation point. Beyond this point, the limiter provides almost constant attenuation, and the output power level will begin to increase proportionally with the input power level until the diodes burn out. The input power level at which the diodes burn out is dependent on frequency, and it decreases with higher frequencies. Thus, the maximum power level of the N9355/6 limiters are specified at their highest frequency of operation. At lower frequencies, the maximum input power level will be higher.

With an RF input pulse, the output pulse is shown in Figure 4.

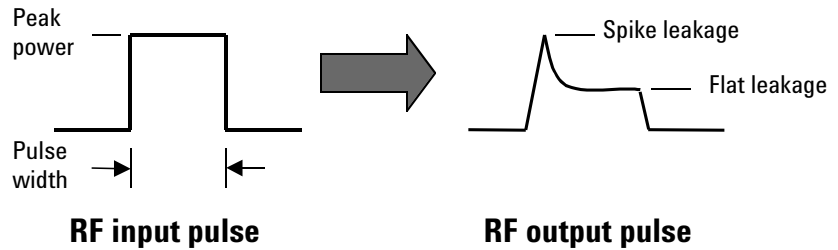

Figure 4. RF input pulse vs. RF output pulse

This is only true when the RF input pulse has a faster rise time than the turn-on time of the limiter. In the event when the limiter turns on faster than the rise time of the pulse, there will be no spike leakage, only flat leakage. The N9355/6 limiters have an extremely fast turn-on time of less than 100 ps, thereby also preventing any spike leakage from damaging the subsequent instrument or component it is protecting. Figure 5 and Figure 6 show the measured turn-on time of the N9355B/C and N9356B/C limiters, which is below 100 ps.

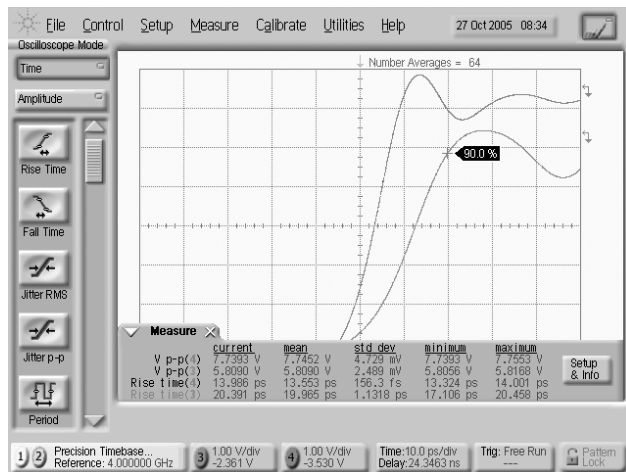

Figure 5. Turn-on time for N9356B/C

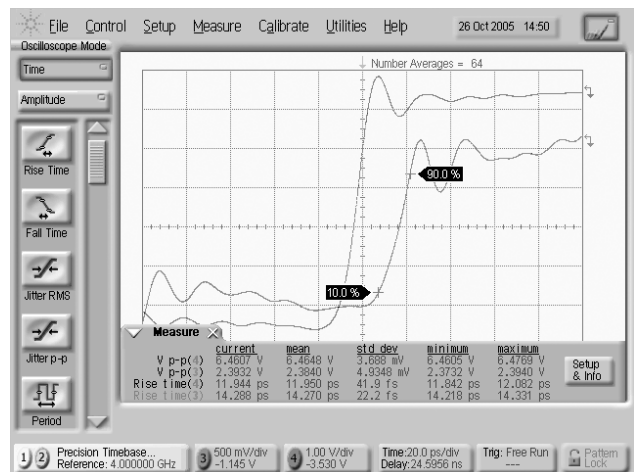

Figure 6. Turn-on time for N9355B/C

ESD

ESD is a high voltage pulse with a very fast rise time. Although very little energy is contained within an ESD pulse, the extremely fast rise time coupled with high voltage can cause failures in unprotected semiconductors inside instruments and devices. Catastrophic destruction can occur immediately as a result of arcing or heating. Even if catastrophic failure does not occur immediately, the device may suffer from parametric degradation, which may result in degraded performance. The cumulative effect of continuous exposure can eventually result in a complete failure. Figure 7 shows the ESD pulse waveform as specified in MIL-STD-883B (Human Body Model) method 3015.7. The rise time of the pulse is less than 10 ns, with the total duration of the pulse less than 500ns.

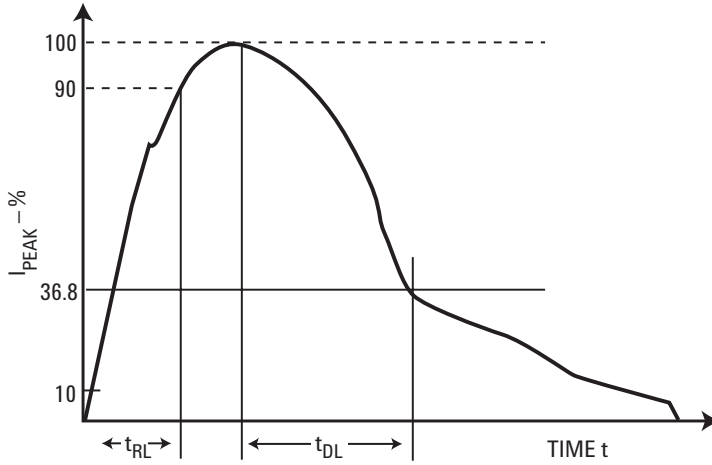

Figure 7. Human body model (MIL-STD-883B) ESD pulse waveform

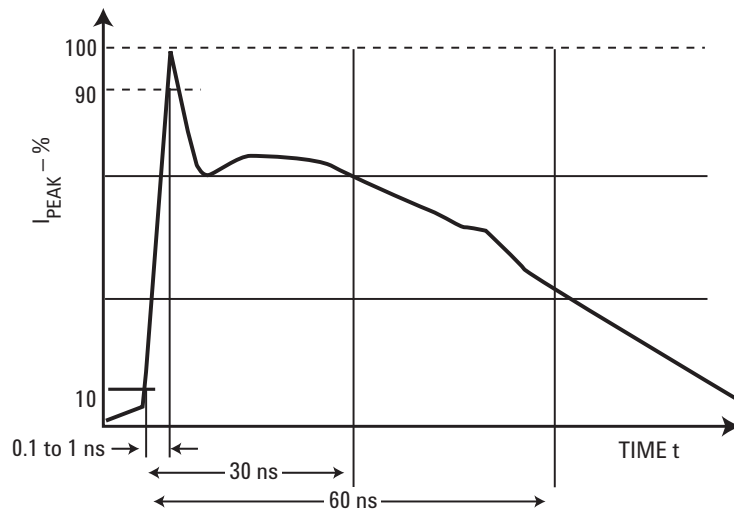

Figure 8. IEC61000-4-2 ESD pulse waveform

Figure 8 shows the ESD pulse waveform as described in IEC61000-4-2. The rise time of the pulse is less than 1 ns, with the total duration of the pulse less than 100 ns. Thus, any device that offers ESD protection must have a rise time of less than 1ns. The Agilent N9355/6 family of limiters all have a rise time of less than 100 ps, thus, offering some level of ESD protection in event of an ESD discharge. However, if the ESD discharge voltage is higher than the ESD susceptibility of the limiters, it is possible that the limiters will be permanently damaged.

Related Product Literature

- 1) *Agilent N9355/6 Power Limiters Technical Overview*, literature number 5989-3637EN
- 2) *Agilent N9355/6 Power Limiter Flyer*, literature number 5989-3740EN

Web Resource

<http://www.agilent.com/find/mta>



Agilent Email Updates

www.agilent.com/find/emailupdates

Get the latest information on the products and applications you select.



Agilent Direct

www.agilent.com/find/agilentdirect

Quickly choose and use your test equipment solutions with confidence.



www.agilent.com/find/open

Agilent Open simplifies the process of connecting and programming test systems to help engineers design, validate and manufacture electronic products. Agilent offers open connectivity for a broad range of system-ready instruments, open industry software, PC-standard I/O and global support, which are combined to more easily integrate test system development.

www.agilent.com

Agilent Technologies' Test and Measurement Support, Services, and Assistance

Agilent Technologies aims to maximize the value you receive, while minimizing your risk and problems. We strive to ensure that you get the test and measurement capabilities you paid for and obtain the support you need. Our extensive support resources and services can help you choose the right Agilent products for your applications and apply them successfully. Every instrument and system we sell has a global warranty. Two concepts underlie Agilent's overall support policy: "Our Promise" and "Your Advantage."

Our Promise

Our Promise means your Agilent test and measurement equipment will meet its advertised performance and functionality. When you are choosing new equipment, we will help you with product information, including realistic performance specifications and practical recommendations from experienced test engineers. When you receive your new Agilent equipment, we can help verify that it works properly and help with initial product operation.

Your Advantage

Your Advantage means that Agilent offers a wide range of additional expert test and measurement services, which you can purchase according to your unique technical and business needs. Solve problems efficiently and gain a competitive edge by contracting with us for calibration, extra-cost upgrades, out-of-warranty repairs, and onsite education and training, as well as design, system integration, project management, and other professional engineering services. Experienced Agilent engineers and technicians worldwide can help you maximize your productivity, optimize the return on investment of your Agilent instruments and systems, and obtain dependable measurement accuracy for the life of those products.

For more information on Agilent Technologies' products, applications or services, please contact your local Agilent office.

Phone or Fax

United States:

(tel) 800 829 4444
(fax) 800 829 4433

Canada:

(tel) 877 894 4414
(fax) 800 746 4866

China:

(tel) 800 810 0189
(fax) 800 820 2816

Europe:

(tel) 31 20 547 2111

Japan:

(tel) (81) 426 56 7832
(fax) (81) 426 56 7840

Korea:

(tel) (080) 769 0800
(fax) (080) 769 0900

Latin America:

(tel) (305) 269 7500

Taiwan:

(tel) 0800 047 866
(fax) 0800 286 331

Other Asia Pacific

Countries:

(tel) (65) 6375 8100
(fax) (65) 6755 0042

Email: tm_ap@agilent.com

Contacts revised: 09/26/05

**The complete list is available at:
www.agilent.com/find/contactus**

Product specifications and descriptions in this document subject to change without notice.

© Agilent Technologies, Inc. 2006
Printed in USA, March 29, 2006
5989-4880EN



Agilent Technologies