



Threshold Sensing For Industrial Control Systems With the HCPL-3700 Interface Optocoupler

INTRODUCTION

The use of electronic logic circuitry in most applications outside of a controlled environment very quickly brings the design engineer into contact with the problems and hazards involved in interfacing between the logic function and the controlled function. These problems have always been particularly evident in the field of industrial control where the electrically "noisy" environment produced by motors, power lines, lightning and other sources of interference may mask the desired signal, and in some cases even result in the destruction of the logic control system itself. In these situations, the designer must resort to solutions which will provide isolation between the logic system and the input or output function. Traditional methods of isolation involve the use of such devices as capacitors, relays, transformers, and optocouplers. Of these methods, the optocoupler provides an ideal combination of speed, dc response, high common mode rejection, and low input to output coupling capacitance.

In the implementation of an interface from an electrically noisy environment into logic systems, it is often desirable, if not mandatory, to establish some current or voltage switching point or threshold at which the input signal is considered true. Since the input, or feedback, signal in industrial control systems may be ac or dc and may range from low, 5 volt, levels to 110 or 240 volts ac, the design of such a threshold switching system can become more than a trivial problem. This is especially true when using the optocoupler, considering the relatively large range of current transfer ratio (CTR) found in most devices.

The problem of establishing an input switching threshold is resolved in the design of the Hewlett-Packard HCPL-3700 optocoupler. This device combines an ac or dc voltage and/or current detection function with a high insulation voltage optocoupler in a single eight pin plastic dual in-line package.

As shown in the block diagram of Figure 1, this device con-

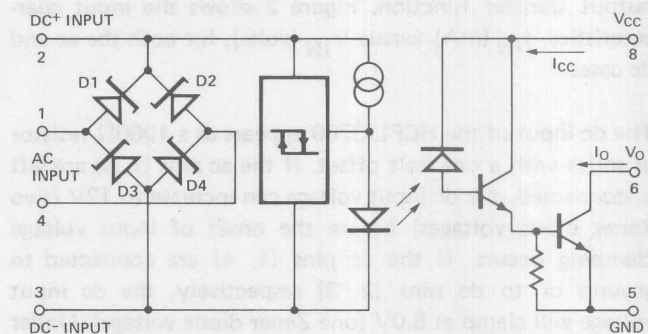

Figure 1. Block Diagram of the HCPL-3700

sists of a full-wave bridge rectifier and threshold detection, integrated circuit, an LED, and an optically coupled detector integrated circuit. The detector circuit is a combination of a photodiode and a high current gain, split Darlington, amplifier.

The input circuit will operate from an ac or dc source and provide a guaranteed, temperature compensated threshold level with hysteresis. The device may be programmed for higher switching thresholds through the use of a single external resistor.

With threshold level detection provided prior to the optical isolation path and subsequent gain stage, variations in the current transfer ratio of the device with time or from unit to unit are no longer important.

In addition to allowing ac or dc input signals, the Zener diodes of the bridge circuit also provide input voltage clamping to protect the threshold circuitry and LED from over voltage/current stress conditions. The LED current is provided by a switched current source.

The HCPL-3700 optocoupler output is an open collector, high gain, split Darlington configuration. The output is compatible with TTL and CMOS logic levels. High common mode rejection, or transient immunity of $600\text{V}/\mu\text{s}$, allows excellent isolation. Insulation capability is 3000 volts dc. The recommended operating temperature range is 0°C to 70°C .

The HCPL-3700 meets the requirements of the industrial control environment for interfacing signals from ac or dc power equipment to logic control electronics. Isolated monitoring of relay contact closure or relay coil voltages, monitoring of limit or proximity switch operation or sensor signals for temperature or pressure, etc., can be accomplished by the HCPL-3700. The HCPL-3700 may also be used for sensing low power line voltage (Brown Out) or loss of line power (Black Out).

Device Characteristics

The function of the HCPL-3700 can best be understood through a review of the input V/I function and the input to output transfer function. Figure 2 shows the input characteristics, I_{IN} (mA) versus V_{IN} (volts), for both the ac and dc cases.

The dc input of the HCPL-3700 appears as a 1000Ω resistor in series with a one volt offset. If the ac pins (1, 4) are left unconnected, the dc input voltage can increase to 12V (two Zener diode voltages) before the onset of input voltage clamping occurs. If the ac pins (1, 4) are connected to ground or to dc pins (2, 3) respectively, the dc input voltage will clamp at 6.0V (one Zener diode voltage). Under clamping conditions, it is important that the maximum input current limits not be exceeded. Also, to prevent excessive current flow in a substrate diode, the dc input can not be backbiased more than -0.5V . The choice of the input voltage clamp level is determined by the requirements of the system design. The advantages of clamping the input at a low voltage level is in limiting the magnitude of forward current to the LED as well as limiting the input power

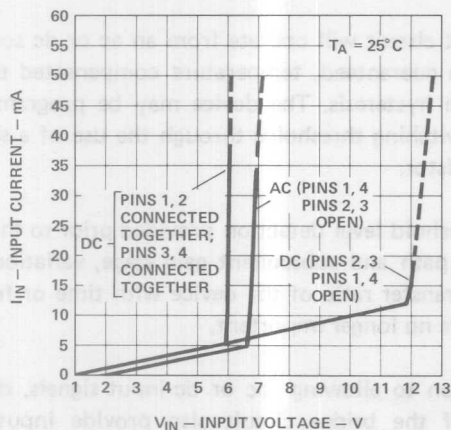

Figure 2. Typical Input Characteristics, I_{IN} vs. V_{IN}

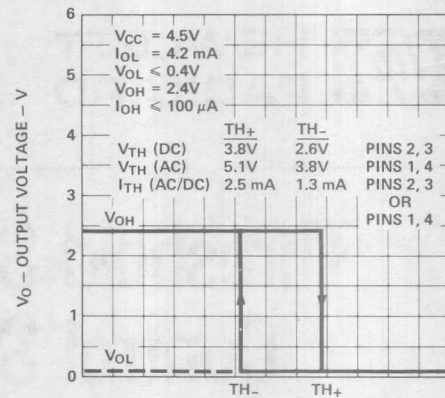

Figure 3. Typical Transfer Characteristics of the HCPL-3700

to the device during large voltage or current transients in the industrial control environment. The internal limiting will in some cases eliminate the need for additional protection components.

The ac input appears similar to the dc input except that the circuit has two additional diode forward voltages. The ac input voltage will clamp at 6.7V (one Zener diode voltage plus one forward biased diode voltage), and is symmetric for plus or minus polarity. The ac voltage clamp level can not be changed with different possible dc pin connections.

The transfer characteristic displayed in Figure 3 shows how the output voltage varies with input voltage, or current, levels. Hysteresis is provided to enhance noise immunity, as well as to maintain a fast transition response (t_r , t_f) for slowly changing input signals.

The hysteresis of the device is given in voltage terms as $V_{HYS} = V_{TH+} - V_{TH-}$, or in terms of current as $I_{HYS} = I_{TH+} - I_{TH-}$. The optocoupler output is in the high state until the input voltage (current) exceeds V_{TH+} (I_{TH+}). The output state will return high when the input voltage (current) becomes less than V_{TH-} (I_{TH-}).

As is shown in Figure 3, the HCPL-3700 has preprogrammed ac and dc switching threshold levels. Higher input switching thresholds may be programmed through the use of a single series input resistance as defined in Equation (1). In some cases, it may be desirable to split this resistance in half to achieve transient protection on each input lead and reduce the power dissipation requirement of each of the resistors.

Figure 4 illustrates three typical interface situations which a designer may encounter in utilizing a microprocessor as a controller in industrial environments.

Example 1. A dc voltage applied to the motor is monitored as an indication of proper speed and/or load condition.

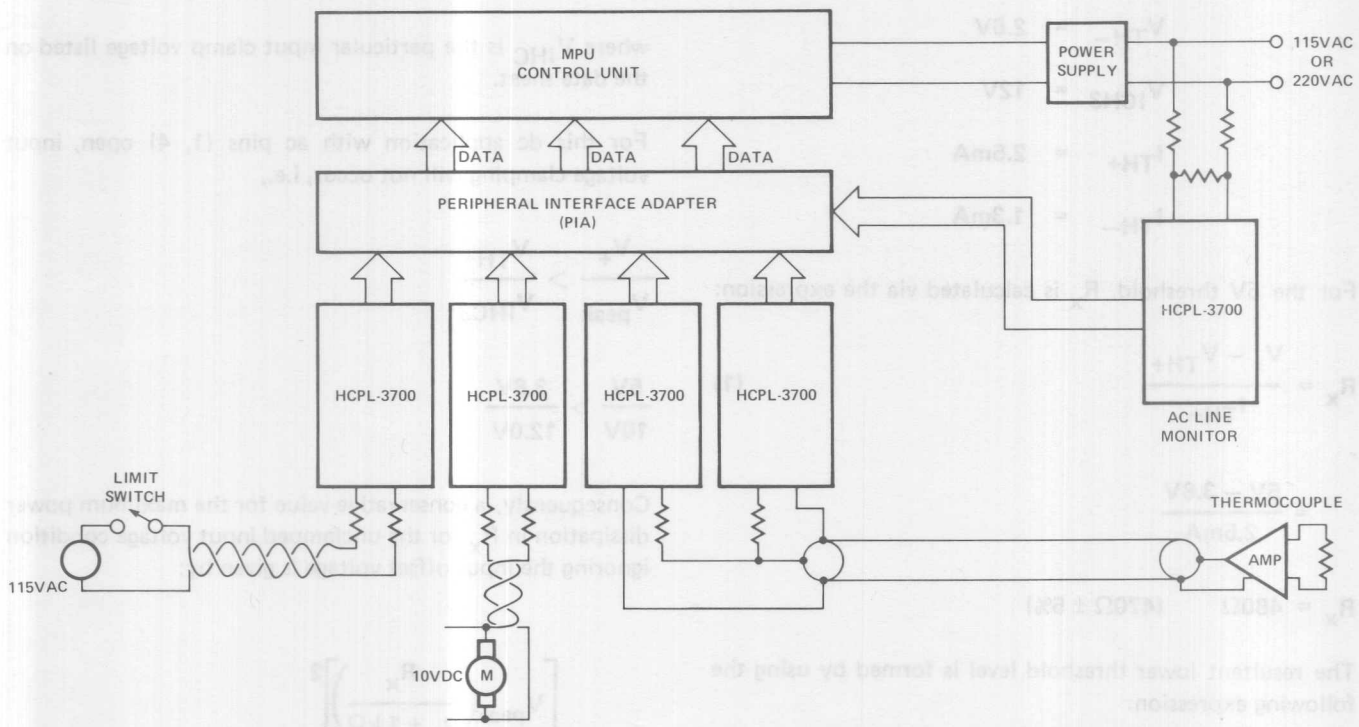

Figure 4. Applications of the HCPL-3700 for Interfacing AC and DC Voltages to a Microprocessor

Example 2. A limit switch uses a 115V ac or 220V ac control loop to improve noise immunity and because it is a convenient high voltage for that purpose.

Example 3. An HCPL-3700 is used to monitor a computer power line to sense a loss of line power condition. Use of a resistive shunt for improvement of threshold accuracy is analyzed in this example.

Also illustrated is an application in which two HCPL-3700's are used to monitor a window of safe operating temperatures for some process parameters. This example also requires a rather precise control of the optocoupler switching threshold. An additional dedicated leased line system example is also shown (Example 4).

Example 1. DC Voltage Sensing

The dc motor monitor function is established to provide an indication that the motor is operating at a minimum desired speed prior to the initiation of another process phase. If the applied voltage, V_M , is greater than 5V, it is assumed that the desired speed is obtained. The maximum applied voltage in the system is 10V. The HCPL-3700 circuit configuration for this dc application is shown in Figure 5.

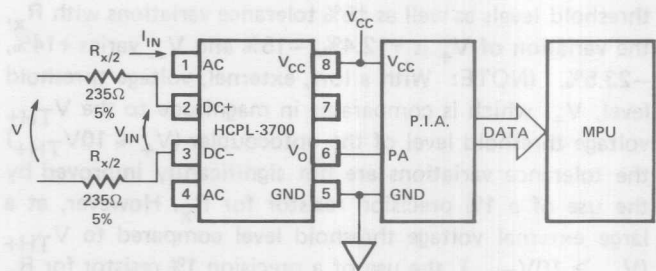

Figure 5. Interfacing a DC Voltage to an MPU using the HCPL-3700

NOTE: See Appendix for a definition of terms and symbols for this and all other examples.

The following conditions are given for the external voltage threshold level and input requirements of the HCPL-3700:

External Voltage Levels – V_M

$$V_+ = 5V \text{ dc (50\%)}$$

$$V_{\text{peak}} = 10V \text{ dc}$$

HCPL-3700 Input Levels

$$V_{TH+} = 3.8V$$

$$V_{TH-} = 2.6V$$

$$V_{ICH3} = 12V$$

$$I_{TH+} = 2.5mA$$

$$I_{TH-} = 1.3mA$$

For the 5V threshold, R_x is calculated via the expression:

$$R_x = \frac{V_+ - V_{TH+}}{I_{TH+}} \quad (1)$$

$$= \frac{5V - 3.8V}{2.5mA}$$

$$R_x = 480\Omega \quad (470\Omega \pm 5\%)$$

The resultant lower threshold level is formed by using the following expression:

$$V_- = I_{TH-} R_x + V_{TH-} \quad (2)$$

$$= (1.3mA) 470\Omega + 2.60V$$

$$V_- = 3.21V$$

With the possible unit to unit variations in the input threshold levels as well as $\pm 5\%$ tolerance variations with R_x , the variation of V_+ is +12.4%, -15% and V_- varies +14%, -23.5%. (NOTE: With a low, external, voltage threshold level, V_+ , which is comparable in magnitude to the V_{TH+} voltage threshold level of the optocoupler ($V_+ \leq 10V_{TH+}$) the tolerance variations are not significantly improved by the use of a 1% precision resistor for R_x . However, at a large external voltage threshold level compared to V_{TH+} ($V_+ > 10V_{TH+}$), the use of a precision 1% resistor for R_x does reduce the variation of V_+ .)

For simultaneous selection of external upper, V_+ , and lower, V_- , voltage threshold points a combination of a series and parallel input resistors can be used. Refer to the example on "ac operation with improved threshold control and accuracy" for detailed information.

Calculation of the maximum power dissipation in R_x is determined by knowing which of the following inequalities is true:

$$\frac{V_+}{V_{peak}} > \frac{V_{TH+}}{V_{IHC}} \quad (V_{IN} \text{ will not clamp}) \quad (3)$$

$$\frac{V_+}{V_{peak}} < \frac{V_{TH+}}{V_{IHC}} \quad (V_{IN} \text{ will clamp}) \quad (4)$$

where V_{IHC} is the particular input clamp voltage listed on the data sheet.

For this dc application with ac pins (1, 4) open, input voltage clamping will not occur, i.e.,

$$\frac{V_+}{V_{peak}} > \frac{V_{TH+}}{V_{IHC3}}$$

$$\frac{5V}{10V} > \frac{3.8V}{12.0V}$$

Consequently, a conservative value for the maximum power dissipation in R_x for the unclamped input voltage condition ignoring the input offset voltage is given by:

$$P_{R_x} = \frac{\left[V_{peak} \left(\frac{R_x}{R_x + 1k\Omega} \right) \right]^2}{R_x} \quad (\text{Unclamped Input}) \quad (5)$$

$$= \frac{\left[10V \left(\frac{470\Omega}{1470\Omega} \right) \right]^2}{470\Omega}$$

$$P_{R_x} = 21.8mW$$

If $V_+/V_{peak} < V_{TH+}/V_{IHC}$ was true (clamped input voltage condition), then the formula for the maximum power dissipation in R_x becomes:

$$P_{R_x} = \frac{(V_{peak} - V_{IHC})^2}{R_x} \quad (\text{Clamped Input}) \quad (6)$$

The maximum input current or power must be determined to ensure that it is within the maximum input rating of the HCPL-3700. For the clamped input voltage condition,

$$I_{IN} = \frac{V_{peak} - V_{IHC}}{R_x} < I_{IN}(\text{max}) \quad (7)$$

or } Clamped Condition

$$P_{IN} = V_{IHC} (I_{IN}) < P_{IN}(\text{max}) \quad (8)$$

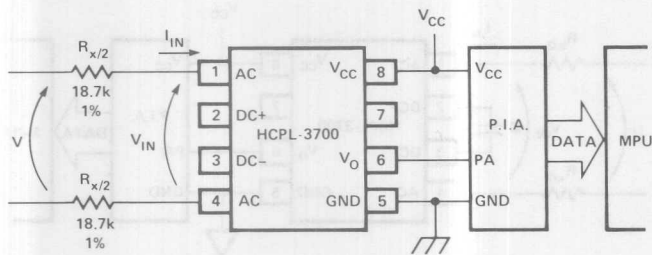

Figure 6. Interfacing an AC Voltage to an MPU using the HCPL-3700

For the unclamped input voltage condition, the maximum input current, or power will not be exceeded, because maximum input current and power will occur only under clamp conditions.

An output load resistance is not needed in this application because the peripheral interface adapter, such as MC6821, has an internal pullup resistor connected to its input.

Example 2. AC Operation

As shown in Figure 6, an ac application is that of a monitored 115V ac limit switch. Ac sensing is commonly used and the HCPL-3700 conveniently provides an internal rectification circuit. With the HCPL-3700 interfacing to the P.I.A., a choice can be made not to filter the ac signal or to filter the ac signal at the input or output of the device. All three conditions will be explored. Simplicity is obtained with no filtering at all, but software detection techniques must be used. Output filtering is a standard method, but may present problems with slow RC rise time of the output waveform when TTL logic is used. Input filtering avoids the RC rise time problem of output filtering, but introduces an extra time delay at the input.

AC Operation With No Filtering

In this example, a V_+ value of 98V is selected based on a criteria of 60% of V_{peak} . Monitoring a limit switch for a 60% level of the signal will give sufficient noise immunity from an open 115V ac line while allowing the HCPL-3700 to turn on under low line voltage conditions of -15% from nominal values when the limit switch is closed.

The value of R_x for the upper threshold detection level without the filter capacitor, C, across the dc input, can be obtained from the following expression.

$$R_x = \frac{V_+ - V_{TH+}}{I_{TH+}} \quad (9)$$

$V_{TH+} = 5.1V$
 (ac instantaneous)
 $I_{TH+} = 2.5mA$

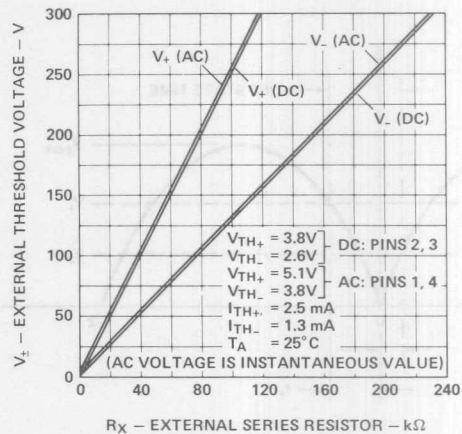

Figure 7. Typical External Threshold Characteristic, V_{\pm} vs. R_x

$$R_x = \frac{98V - 5.1V}{2.5mA}$$

$$R_x = 37.2k\Omega \quad (\text{use } R_x/2 = 18.7k\Omega, 1\% \text{ resistor for each input lead})$$

The resulting lower threshold point is

$$V_- = I_{TH-} R_x + V_{TH-} \quad (10)$$

$$= (1.3mA)(37.4k\Omega) + 3.8V$$

$$V_- = 52.4V \quad (32\% \text{ of peak input voltage})$$

Figure 7 provides a convenient, graphical choice for the external series resistor, R_x , and a particular external threshold voltage V_{\pm} .

The corresponding R_x value and output waveform of the HCPL-3700 for a $V_+ = 98V$ (60% of peak) is shown in Figure 8.

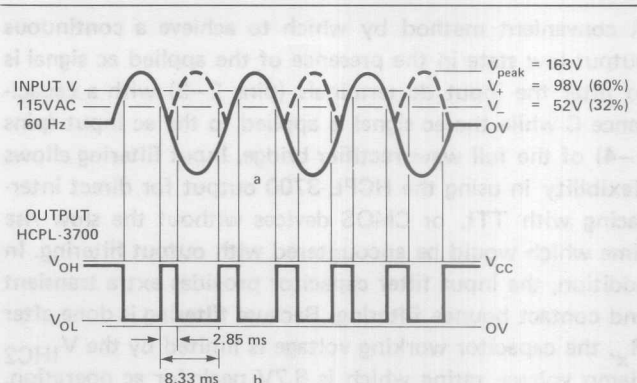

Figure 8. Output Waveforms of the HCPL-3700 Design in Figure 7 with no Filtering Applied

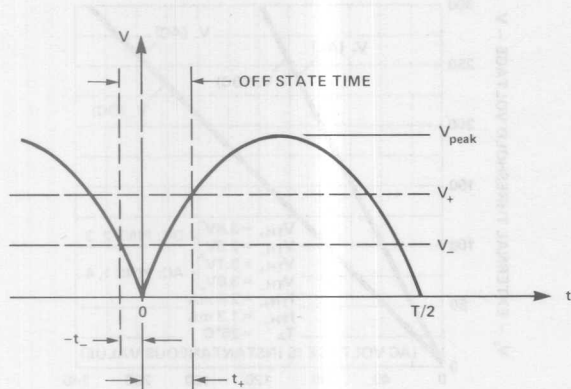

Figure 9. Determination of Off/On State Time

To determine the time in the high state, refer to Figure 9 and Equation (11).

Due to symmetry of sinusoidal waveform, the high state time is $t_- + t_+$ where t_{\pm} is given by:

$$t_{\pm} = \frac{T}{360^\circ} \sin^{-1} \left(\frac{V_{\pm}}{V_{\text{peak}}} \right) \quad (11)$$

where arc sine is in degrees and T = period of sinusoidal waveform.

In the unfiltered condition, the output waveform of Figure 8 must be used as sensed information. Software can be created in which the microprocessor will examine the waveform from the optocoupler at specific intervals to determine if ac is present or absent at the input to the HCPL-3700. This technique eliminates the problem of filtering, and accompanying delays, but requires more sophisticated software implementation in the microprocessor.

Input Filtering for AC Operation

A convenient method by which to achieve a continuous output low state in the presence of the applied ac signal is to filter the input dc terminals (pins 2–3) with a capacitance C while the ac signal is applied to the ac input (pins 1–4) of the full wave rectifier bridge. Input filtering allows flexibility in using the HCPL-3700 output for direct interfacing with TTL or CMOS devices without the slow rise time which would be encountered with output filtering. In addition, the input filter capacitor provides extra transient and contact bounce filtering. Because filtering is done after R_x , the capacitor working voltage is limited by the V_{IHC2} clamp voltage rating which is 6.7V peak for ac operation. The disadvantage of input filtering is that this technique introduces time delays at turn on and turn off of the optocoupler due to initial charge/discharge of the input filter capacitor.

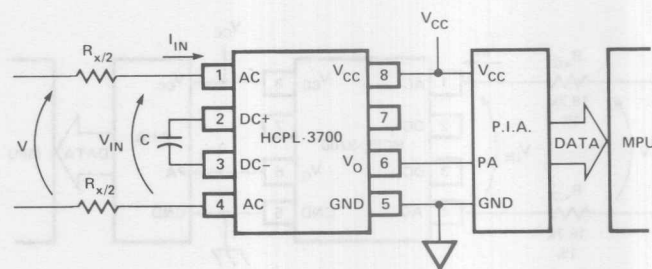

Figure 10. Input Filtering with the HCPL-3700

The application of ac input filtering is illustrated in Figure 10 and is described in the following example. The ac input conditions are the same as in the previous example of the 115V ac limit switch.

The minimum value of capacitance C to ensure proper ac filtering is determined by the parameters of the optocoupler. At low ac input voltage, the capacitor must charge to at least $V_{\text{TH+}}$ in order to turn on, but must not discharge to $V_{\text{TH-}}$ during the discharge cycle. A conservative estimate for the minimum value of C is given by the following equations.

$$V_{\text{TH+}} - V_{\text{TH-}} = V_{\text{TH+}} e^{-t/\tau}, \quad \tau = R_{\text{IN}} C_{\text{min}} \quad (12)$$

where R_{IN} is the equivalent input resistance of the HCPL-3700.

$$C_{\text{min}} = \frac{t}{R_{\text{IN}} \ln \left(\frac{V_{\text{TH+}}}{V_{\text{TH+}} - V_{\text{TH-}}} \right)} \quad (13)$$

with $R_{\text{IN}} = 1\text{k}\Omega$, $V_{\text{TH+}} = 3.8\text{V}$, $V_{\text{TH-}} = 2.6\text{V}$ and $t = 8.33\text{ms}$ for 60 Hz or $t = 10\text{ms}$ for 50 Hz.

$$C_{\text{min}} = 7.23\mu\text{F} \text{ for } 60 \text{ Hz}$$

$$C_{\text{min}} = 8.68\mu\text{F} \text{ for } 50 \text{ Hz}$$

To ensure proper filtering, the recommended value of C should be large enough such that with the tolerance variation, C will always be greater than C_{min} (C should otherwise be kept as small as possible to minimize the inherent delay times which are encountered with this technique). Since the filter capacitor affects the input impedance, a slightly different value of R_x is required for the input filtered condition. Figure 11 shows the R_x versus V_{\pm} threshold voltage for $C = 10\mu\text{F}$, $22\mu\text{F}$, and $47\mu\text{F}$. For an application of monitoring a 115V RMS line for 65% of nominal voltage condition (75V RMS), an $R_x = 26.7\text{k}\Omega \pm 1\%$ with $C = 10\mu\text{F}$ will yield the desired threshold. The power dissipation for R_x is determined from the clamped

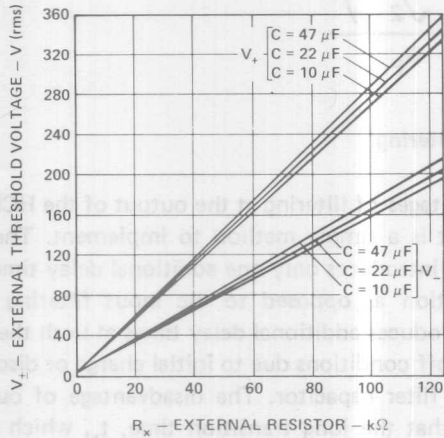

Figure 11. External Threshold Voltage versus R_x for Applications Using an Input Filter Capacitor C (Figure 10)

condition ($V_+/V_{peak} < V_{TH+}/V_{ICH2}$) and is 455mW (see Figure 6) which suggests $R_x/2$ of 1/2 watt resistors for each input lead.

Example 3. AC Operation with Improved Threshold Control and Accuracy

Some applications may occur which require threshold level detection at specific upper and lower threshold points. The ability to independently set the upper and lower threshold levels will provide the designer with more flexibility to meet special design criteria. As illustrated in Figure 12, a computer power line is monitored for a power failure condition in order to prevent loss of memory information during power line failure.

In this design, the HCPL-3700 optocoupler monitors the computer power line and the output of the optocoupler is interfaced to a TTL Schmitt trigger gate (7414).

In the earlier ac application of the HCPL-3700 (limit switch example), a single external series resistor, R_x , was used to determine one of the threshold levels. The other threshold level was determined by the hysteresis of the device, and not the designer. A potential problem of single threshold

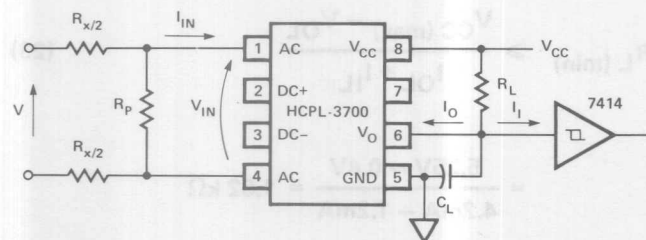

Figure 12. An AC Power Line Monitor with Simultaneous Selection of Upper and Lower Threshold Levels and Output Filtering

selection with 115V line application would be to determine R_x for a lower threshold level of 50% of nominal peak input voltage, only to find that the upper threshold level is 90% of peak input voltage. With the possible ac line voltage variations (+10%, -15%), it would be possible that the optocoupler could never reach the upper threshold point with an ac line that is at -15% of nominal value. To give the designer more control over both threshold points, a combination of series resistance, R_x , and parallel resistance, R_p , may be used, as shown in Figure 12.

Two equations can be written for the two external threshold level conditions. At the upper threshold point,

$$V_+ = R_x \left(I_{TH+} + \frac{V_{TH+}}{R_p} \right) + V_{TH+} \quad (14)$$

and at the lower threshold point,

$$V_- = R_x \left(I_{TH-} + \frac{V_{TH-}}{R_p} \right) + V_{TH-} \quad (15)$$

Solving these equations for R_x and R_p yield the following expressions:

$$R_x = \frac{V_{TH-}(V_+) - V_{TH+}(V_-)}{I_{TH+}(V_{TH-}) - I_{TH-}(V_{TH+})} \quad (16)$$

$$R_p = \frac{V_{TH-}(V_+) - V_{TH+}(V_-)}{I_{TH+}(V_- - V_{TH-}) + I_{TH-}(V_{TH+} - V_+)} \quad (17)$$

Equations (16) and (17) are valid only if the conditions of Equations (18) or (19) are met. The desired external voltage threshold levels, V_+ and V_- , are established and the values for $V_{TH\pm}$ and $I_{TH\pm}$ are found from the data sheet. With the $V_{TH\pm}$, $I_{TH\pm}$ values, the denominator of R_x , Equation (16) is checked to see if it is positive or negative. If it is positive, then the following ratios must be met:

$$\frac{V_+}{V_-} \geq \frac{V_{TH+}}{V_{TH-}} \quad \text{and} \quad \frac{V_+ - V_{TH+}}{V_- - V_{TH-}} < \frac{I_{TH+}}{I_{TH-}} \quad (18)$$

Conversely, if the denominator of R_x , Equation (16) is negative, then the following ratios must hold:

$$\frac{V_+}{V_-} \leq \frac{V_{TH+}}{V_{TH-}} \quad \text{and} \quad \frac{V_+ - V_{TH+}}{V_- - V_{TH-}} > \frac{I_{TH+}}{I_{TH-}} \quad (19)$$

Consider that the computer power line is monitored for a 50% line drop condition and a 75% line presence condition. The 115V 60 Hz ac line (163V peak) can vary from 85% (139V) to 110% (179V) of nominal value.

Require:

$$V_- = 81.5V \quad (50\%) \quad - \quad \text{Turn off threshold}$$

$$V_+ = 122.5V \quad (75\%) \quad - \quad \text{Turn on threshold}$$

Given:

$$V_{TH+} = 5.1V \quad I_{TH+} = 2.5mA \quad V_{IHC2} = 6.7V$$

$$V_{TH-} = 3.8V \quad I_{TH-} = 1.3mA$$

Using the Equations (16, 17) for R_x , R_p with the conditions of Equations (18, 19) being met yields

$$R_x = 17.4 \text{ k}\Omega \quad \text{use } 18 \text{ k}\Omega \quad 5\%$$

$$R_p = 1.2 \text{ k}\Omega \quad \text{use } 1.2 \text{ k}\Omega \quad 5\%$$

To complete the input calculations for maximum input current, I_{IN} , to the device and maximum power dissipation in R_x and R_p , a check must be made to determine if the input voltage will clamp at peak applied voltage. Using Equations (3) and (4) to determine if a clamp or no clamp exists, it is found that the ratios

$$0.75 = \frac{V_+}{V_{peak}} \approx \frac{V_{TH+}}{V_{IHC2}} = 0.76$$

indicate that V_{IN} slightly entered clamp condition. In this application, the operating input current, I_{IN} , is given approximately by

$$I_{IN} = \frac{V - \frac{V_{IHC2}}{\sqrt{2}}}{R_x} - \frac{V_{IHC2}}{R_p} < I_{IN}(\text{max}) \quad (20)$$

$$= \frac{115V - \frac{6.7V}{\sqrt{2}}}{18 \text{ k}\Omega} - \frac{6.7V}{1.2 \text{ k}\Omega}$$

$$I_{IN} = 2.18mA \text{ RMS} < 34.3mA$$

Power dissipation in R_x is determined from the following equation,

$$P_{R_x} = \frac{\left(V - \frac{V_{IHC2}}{\sqrt{2}}\right)^2}{R_x} \quad (21)$$

which yields 0.675W. With the clamp condition existing, the maximum power dissipation for R_p is 18.7mW which is determined from

$$P_{R_p} = \frac{\left(\frac{V_{IHC2}}{\sqrt{2}}\right)^2}{R_p} \quad (22)$$

Output Filtering

The advantages of filtering at the output of the HCPL-3700 are that it is a simple method to implement. The output waveform introduces only one additional delay time at turn off condition as opposed to the input filtering method which introduces additional delay times at both the turn on and turn off conditions due to initial charge or discharge of the input filter capacitor. The disadvantage of output filtering is that the long transition time, t_r , which is introduced by the output RC filter requires a Schmitt trigger logic gate to buffer the output filter circuit from the subsequent logic circuits to prevent logic chatter problems. The determination of load resistance and capacitance is illustrated in the following text.

The following given values specify the interface conditions.

HCPL-3700

$$V_{OL} = 0.4V$$

$$I_{OL} = 4.2mA$$

$$I_{OH} = 100\mu A \text{ max}$$

$$V_{CC} = 5.0V \pm 5\%$$

7414

$$V_{T+}(\text{min}) = 1.5V$$

$$V_{T+}(\text{max}) = 2.0V$$

Schmitt trigger upper

threshold level

$$I_{IH} = 40\mu A \text{ max}$$

$$I_{IL} = -1.2mA \text{ max}$$

With the current convention shown in Figure 12, the minimum value of R_L which ensures that the output transistor remains in saturation is:

$$R_L(\text{min}) \geq \frac{V_{CC}(\text{max}) - V_{OL}}{I_{OL} + I_{IL}} \quad (23)$$

$$= \frac{5.25V - 0.4V}{4.2mA - 1.2mA} = 1.62 \text{ k}\Omega$$

The maximum value for R_L is calculated allowing for a guardband of 0.4V in $V_{T+}(\text{max})$ parameter, or $V_{IH} = V_{T+}(\text{max}) + 0.4V$.

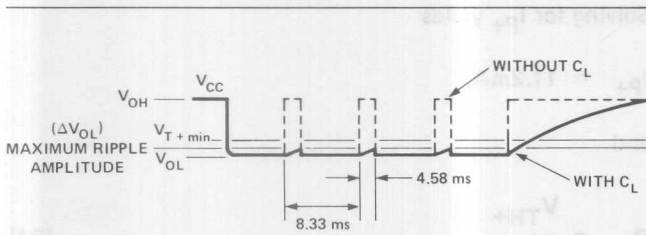

Figure 13. Output Waveforms of the HCPL-3700

$$R_L (\text{max}) \leq \frac{V_{CC} (\text{min}) - V_{IH}}{I_{OH} - I_{IH}} \quad (24)$$

$$= \frac{4.75\text{V} - 2.4\text{V}}{0.1\text{mA} + 0.04\text{mA}} = 16.8 \text{ k}\Omega$$

R_L is chosen to be 1650 Ω .

C_L can be determined in the following fashion. As illustrated in Figure 8, the output of the optocoupler will be in the high state for a specific amount of time dependent upon the selected V_+ levels. In this example, $V_+ = 122.5\text{V}$ (75%) and $V_- = 81.5\text{V}$ (50%) and allowing for a minimum peak line voltage of 138V (-15%), the high state time (without C_L) is from Equation (11), 4.58ms. With the appropriate C_L value, the output waveform (solid line) shown in Figure 13 is filtered.

The maximum ripple amplitude above V_{OL} is chosen to be 0.6V; that is, $V_{OL} + \Delta V_{OL} = 1.0\text{V}$. This gives a 0.5V noise margin before $V_{T+} (\text{min}) = 1.5\text{V}$ is reached. The exponential ripple waveform is caused by the C_L being charged through R_L and input resistance, R_{INTTL} , of TTL gate. An expression for the allowable change in V_{OL} can be written:

$$\Delta V_{OL} = (V_{OH} - V_{OL}) (1 - e^{-t/\tau}) \quad (25)$$

where $\tau = R'_L C_L$ with R'_L equal to parallel combination of R_L and R_{INTTL} .

Below $V_{T+} = 1.5\text{V}$ (min), R_{INTTL} is constant and nominally 6 k Ω . Hence:

$$R'_L = \frac{R_L R_{INTTL}}{R_L + R_{IN}} \quad (26)$$

$$= \frac{(1.65 \text{ k}\Omega) (6 \text{ k}\Omega)}{1.65 \text{ k}\Omega + 6 \text{ k}\Omega}$$

$$R'_L = 1.29 \text{ k}\Omega$$

Solving Equation (25) for τ yields

$$\tau = \frac{t}{\ln \left(\frac{V_{OH} - V_{OL}}{V_{OH} - V_{OL} - \Delta V_{OL}} \right)} \quad (27)$$

and substituting previous parameter values and using $V_{OH} = V_{CC} - (I_{OH} + I_{IH}) R_L$ results in

$$= \frac{4.58\text{ms}}{\ln \left(\frac{4.8\text{V} - 0.4\text{V}}{4.8\text{V} - 0.4\text{V} - 0.6\text{V}} \right)}$$

$$\tau = 31.24\text{ms}$$

C_L can be calculated directly,

$$C_L = \frac{\tau}{R'_L} \quad (28)$$

$$= \frac{31.24\text{ms}}{1.29 \text{ k}\Omega}$$

$$C_L = 24.2\mu\text{F} \quad \text{use } 27\mu\text{F} \pm 10\% \\ \text{or } 33\mu\text{F} \pm 20\%$$

With this value of C_L , the time the $R'_L C_L$ filter network takes to reach V_{T+} of the TTL gate is found as follows.

$$V_{OL} + (V_{OH} - V_{OL}) (1 - e^{-t/\tau}) = V_{T+} \quad (29)$$

Solving for t ,

$$t = \tau \ln \left(\frac{V_{OH} - V_{OL}}{V_{OH} - V_{T+} (\text{min})} \right) \quad (30)$$

and substituting $V_{OH} = 4.8\text{V}$, $V_{OL} = 0.4\text{V}$, $V_{T+} (\text{min}) = 1.5\text{V}$, and $\tau = 31.24\text{ms}$ yields

$$t = 9.0\text{ms}$$

This is the delay time that the system takes to respond to the ac line voltage going below the 50% (V_-) threshold level. In essence, the response time is slightly more than a half cycle (8.33ms) of 60 Hz ac line with worst case line variation taken into account. This delay time is acceptable for system power line protection. In this example, a complete worst case analysis was not performed. A worst case analysis should be done to ensure proper function of the circuit over variations in line voltage, unit to unit device parameter variations, component tolerances and temperature.

Threshold Accuracy Improvement

In the above example on output filtering, the two external threshold levels were selected for turn on conditions at $V_+ = 122.5V$ (75%) and turn off at $V_- = 81.5V$ (50%). The calculated external resistor values were $R_x = 17.4 k\Omega$ and $R_p = 1.2 k\Omega$. Using standard 5% resistors of $18 k\Omega$ and $1.2 k\Omega$ respectively, the upper threshold voltage was actually 126.6V nominal.

Examination of the worst possible combination of variations of the HCPL-3700 optocoupler V_{TH+} , I_{TH+} , levels from unit to unit, and the $\pm 5\%$ variations of R_x and R_p can result in the V_+ level changing +23% to -25% from design nominal.

If higher threshold accuracy is desired, it can be accomplished by decreasing the value of R_p in order to allow R_p to dominate the input resistance variations of the optocoupler. Using a 1% resistor for R_p and resistance of sufficiently small magnitude, the V_+ tolerance variations can be significantly improved. The following analysis will allow the designer to obtain nearly optimum threshold accuracy from unit to unit. It should be noted that the HCPL-3700 demonstrates excellent threshold repeatability once the external resistors are adjusted for a particular level and unit. The compromise which is made for the added control on threshold accuracy is that more input power must be consumed within the R_p , R_x resistors.

In Figure 14, assume the circuit is at the upper threshold point. At constant V_{TH+} , it is desired to maintain I_+ to within $\pm 5\%$ variation of nominal value while allowing $\pm 1\%$ variation in I_{p+} . With this requirement, Equations (31) and (32) can be written and solved for the magnitude of I_{p+} which is needed to maintain the desired condition on I_+ . I_+ is the sum of I_{p+} and I_{TH+} .

$$1.05 I_+ = 1.01 I_{p+} + I_{TH+} (\text{max}) \quad (31)$$

$$0.95 I_+ = 0.99 I_{p+} + I_{TH+} (\text{min}) \quad (32)$$

} at constant V_{TH+}

where

$$I_{TH+} (\text{max}) = 3.11\text{mA}$$

$$I_{TH+} (\text{min}) = 1.96\text{mA}$$

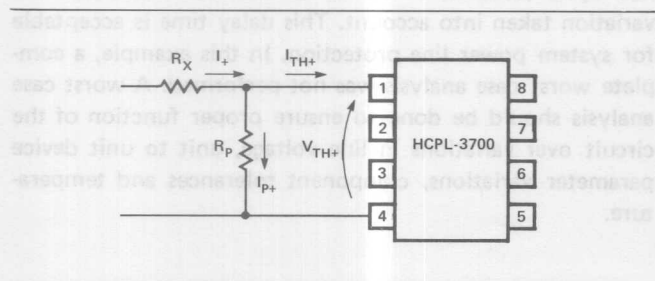

Figure 14. Threshold Accuracy Improvement through the Use of External R_x and R_p Resistors

Solving for I_{p+} yields

$$I_{p+} = 11.2\text{mA},$$

and

$$R_p = \frac{V_{TH+}}{I_{p+}} \quad (33)$$

$$= \frac{5.1V}{11.2\text{mA}}$$

$$R_p = 433\Omega \quad (\text{use } 453\Omega, 1\% \text{ resistor})$$

This new value of R_p replaces the earlier $R_p = 1.2 k\Omega$, and the circuit requires a new R_x value to maintain the same V_+ threshold level.

$$R_x = \frac{V_+ - V_{TH+}}{I_+} \quad \text{where } I_+ = I_{p+} + I_{TH+} \quad (34)$$

$$= 11.2\text{mA} + 2.5\text{mA}$$

$$= \frac{122.5V - 5.1V}{13.7\text{mA}}$$

$$R_x = 8.57 k\Omega \quad (\text{use } 8.66 k\Omega, 1\% \text{ resistor})$$

With the possible variation of $\pm 1\%$ in R_p and R_x , as well as unit to unit variations in the optocoupler V_{TH+} , I_{TH+} , the upper threshold level V_+ will vary significantly less than in the 5% resistor design case. The variations in V_+ , which is given by $V_+ = R_x I_+ + V_{TH+}$, where $I_+ = I_{p+} + I_{TH+}$, are compared in Table 1.

Table 1 illustrates the possible improvements in V_+ tolerance as R_x and R_p are adjusted to limit the variation of the external input threshold current, I_+ , to the resistor network and optocoupler. This table is centered at a nominal external input threshold voltage of $V_+ = 122.5V$. It is the designer's compromise to keep power consumption low, but threshold accuracy high.

NOTE: The above method for selection of R_p and R_x can be adapted for applications where larger sense currents (wet sensing) may be appropriate.

Example 4. Dedicated Lines for Remote Control

In situations involving a substantial separation between the signal source and the receiving station, it may be desirable to lease a dedicated private line metallic circuit (dc path) for supervisory control of remote equipment. The HCPL-3700 can provide the interface requirements of voltage threshold detection and optical isolation from the metallic line to the remote equipment. This greatly reduces the expense of using a sophisticated modem system over a convention telephone line.

R_x	T O L.	R_p	T O L.	I_+ TOLERANCE	V_+ TOLERANCE		MAXIMUM TOTAL POWER IN $R_x + R_p$ (RMS)
18 k Ω	5%	1.2 k Ω	5%	+17.5% -21.2%	+ 23%	- 25%	0.69 W
8.66 k Ω	1%	453 Ω	1%	$\pm 5\%$	+12.7%	-19.3%	1.45 W
4.32 k Ω	1%	205 Ω	1%	$\pm 3\%$	+11.2%	-18.9%	2.92 W
2.15 k Ω	1%	97.5 Ω	1%	$\pm 2\%$	+10.6%	-18.8%	5.89 W

Table 1. Comparison of the V_+ Threshold Accuracy Improvement versus R_x and R_p and Power Dissipation for a Nominal $V_+ = 122.5$ V

Figure 15 represents the application of the HCPL-3700 for a line which is to control tank levels in a water district.

Some comments are needed about dedicated metallic lines. The use of a private metallic line places restrictions upon the designer's signal levels. The line in this example would be used in the interrupted dc mode (duration of each interruption greater than one second), the maximum allowed voltage between any conductor and ground is ≤ 135 volts. Maximum current should be limited to 150mA if the cable has compensating inductive coils in it. Balanced operation of the line is strongly recommended to reduce possible cross talk interference as well as to allow larger signal magnitudes to be used. Precaution also should be taken to protect the line and equipment. The line needs to be fused to ensure against equipment failure causing excessive current to flow through telephone company equipment. In addition, protection from damaging transients must be taken via spark gap arrestors and commercial transient suppressors. Details of private line metallic circuits can be founded in the American Telephone and Telegraph Company publication 43401.

In this application, a 48V dc floating power source supplies the signal for the metallic line. The HCPL-3700 upper voltage threshold level is set for $V_+ = 36$ V (75%). Consequently, R_x is

$$R_x = \frac{V_+ - V_{TH+}}{I_{TH+}} \quad (35)$$

$$= \frac{36V - 3.8V}{2.5mA}$$

$$= 12.9 \text{ k}\Omega$$

(use $R_x/2 = 6.49 \text{ k}\Omega$, 1% resistor in each input level)

The resulting lower voltage threshold level is

$$V_- = R_x I_{TH-} + V_{TH-} \quad (36)$$

$$= 13 \text{ k}\Omega (1.3mA) + 2.6V$$

$$V_- = 19.5V$$

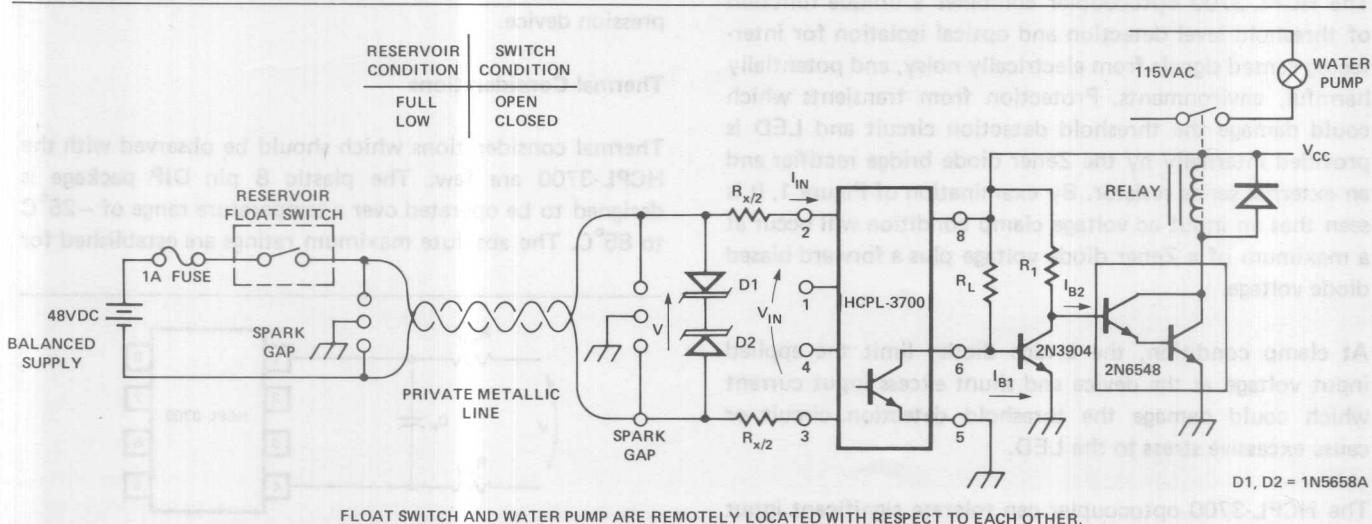

Figure 15. Application of the HCPL-3700 to Private Metallic Telephone Circuits for Remote Control

yielding $V_{HYS} = 16.5V$. The average induced ac voltage from adjacent power lines is usually less than 10 volts (reference ATT publication 43401) which would not falsely turn on, or off, the HCPL-3700, but could affect conventional optocouplers.

Under normal operation (full reservoir), the optocoupler is off. When the float switch is closed (low reservoir), the optocoupler output (V_{OL}) needs inversion, via a transistor, to drive the power Darlington transistor which controls a motor starting relay. The relay applies ac power to the system water pump. With $V_{CC} = 10V$, $I_{B2} = 0.5mA$, $I_{B1} = 0.5mA$.

$$R_1 = \frac{V_{CC} - 2V_{BE}}{I_{B2}} \quad (37)$$

$$= \frac{10V - 1.4V}{0.5mA}$$

$$R_1 = 17.2 \text{ k}\Omega$$

$$(R_1 = 18 \text{ k}\Omega)$$

$$R_L = \frac{V_{CC} - V_{BE}}{I_{B1}} \quad (38)$$

$$= \frac{10V - 0.7V}{0.5mA}$$

$$R_L = 18.6 \text{ k}\Omega$$

$$(R_L = 18 \text{ k}\Omega)$$

For this application, the ac inputs could also be used, which would remove any concern about the polarity of the input signal.

General Protection Considerations for the HCPL-3700

The HCPL-3700 optocoupler combines a unique function of threshold level detection and optical isolation for interfacing sensed signals from electrically noisy, and potentially harmful, environments. Protection from transients which could damage the threshold detection circuit and LED is provided internally by the Zener diode bridge rectifier and an external series resistor. By examination of Figure 1, it is seen that an input ac voltage clamp condition will occur at a maximum of a Zener diode voltage plus a forward biased diode voltage.

At clamp condition, the bridge diodes limit the applied input voltage at the device and shunt excess input current which could damage the threshold detection circuit or cause excessive stress to the LED.

The HCPL-3700 optocoupler can tolerate significant input current transient conditions. The maximum dc input current into or out of any lead is 50mA. The maximum

input surge current is 140mA for 3ms at 120 Hz pulse repetition rate, and the maximum input transient current is 500mA for 10 μ s at 120 Hz pulse repetition rate. The use of an external series resistor, R_x , provides current limiting to the device when a large voltage transient is present. The amplitude of the acceptable voltage transient is directly proportional to the value of R_x .

However, in order to protect the HCPL-3700 when the input voltage to the device is clamped, the maximum input current must not be exceeded. An external means by which to enhance transient protection can be seen in Figure 16.

A transient $R_x C_p$ filter can be formed with C_p chosen by the designer to provide a sufficiently low break point for the low pass filter to reduce high frequency transients. However, the break point must not be so low as to attenuate the signal frequency. Consider the previous ac application where no filtering was used. In that application, $R_x = 37.4 \text{ k}\Omega$, and if the bandwidth of the transient filter needs to be 600 Hz, then C_p is:

$$C_p = \frac{1}{2\pi f R_x} \quad (39)$$

$$C_p = 0.0071\mu F \quad (\text{use } 0.0068\mu F \text{ capacitor @ } 50V \text{ dc})$$

Should additional protection be needed, a very effective external transient suppression technique is to use a commercial transient suppressor, such as a Transzorb[®], or metal oxide varistor, MOV[®], at the input to the resistor network prior to the optocoupler. The Transzorb[®] will provide extremely fast transient response, clamp the input voltage to a definite level, and absorb the transient energy. Selection of a Transzorb[®] is made by ensuring that the reverse stand off voltage is greater than the continuous peak operating voltage level. Transzorbs[®] can be stacked in series or parallel for higher peak power ratings. Depending upon the designer's potential transient problems, a solution may warrant the expense of a commercial suppression device.

Thermal Considerations

Thermal considerations which should be observed with the HCPL-3700 are few. The plastic 8 pin DIP package is designed to be operated over a temperature range of $-25^\circ C$ to $85^\circ C$. The absolute maximum ratings are established for

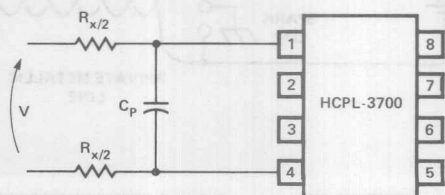

Figure 16. $R_x C_p$ Transient Filter for the HCPL-3700

a 70°C ambient temperature requiring slight derating to 85°C. In general, if operation of the HCPL-3700 is at ambient temperature of 70°C or less, no heat sinking is required. However, for operation between 70°C and 85°C ambient temperature, the maximum ratings should be derated per the data sheet specifications.

Mechanical and Safety Considerations

Mechanical Mounting Considerations

The HCPL-3700 optocoupler is a standard 8 pin dual-in-line plastic package designed to interface ac or dc power systems to logic systems. This optocoupler can be mounted directly onto a printed circuit board by wave soldering.

Electrical Safety Considerations

Special considerations must be given for printed circuit board lead spacing for different safety agency requirements. Various standards exist with safety agencies (U.L., V.D.E., I.E.C., etc.) and should be checked prior to PC board layout. The HCPL-3700 optocoupler component is recognized under the Component Program of Underwriters Laboratories, Inc. in file number E55361. This file qualifies the component to specific electrical tests to 220V ac operation.

The spacing required for the PC board leads depends upon the potential difference that would be observed on the board. Some standards that could pertain to equipment which would use the HCPL-3700 are UL1244, Electrical and Electronic Measuring and Testing Equipment, UL1092, Process Control Equipment, and IEC348, Electronic Measuring Apparatus. Spacing for the worst case in an uncontrolled environment with a 2000 volt-amperes maximum supplying source rating must be 3.2mm (0.125 inches) for 51 – 250 volts RMS potential difference over a surface (creepage distance), and 3mm (0.118 inches)

through air (bare wire). These separations are between any uninsulated live part and uninsulated live part of opposite polarity, or uninsulated ground part other than the enclosure or an exposed metal part.

An uncontrolled environment is an environment which has contaminants, chemical vapors, particulates or any substances which would cause corrosion, decrease resistance between PC board traces or, in general, be an unhealthy environment to human beings.

For 0 – 50 volts RMS, the spacing is 1.6mm (0.063 inches) through air or over surfaces.

Electrical Connectors

The HCPL-3700 provides the needed isolation between a power signal environment and a control logic system. However, there exists a physical requirement to actually interconnect these two environments. This interconnection can be accomplished with barrier strips, edge card connectors, and PCB socket connectors which provide the electrical cable/field wire connection to the I/O logic system. These connectors provide for easy removal of the PC board for repair or substitution of boards in the I/O housing and are needed to satisfy the safety agency (U.L., V.D.E., I.E.C.) requirements for spacing and insulation. Connectors are readily available from many commercial manufacturers, such as Connection Inc., Buchanan, etc. The style of connector to choose is dependent upon the application for which the PC board is used. If possible it is wise to choose a style which does not mount to the PC board. This would enable the PC card to be removed without having to disconnect field wires. The use of connectors which are called "gas tight connectors" provide for good electrical and mechanical reliability by reducing corrosion effects over time.

APPENDIX I. List of Parameters

- V ≡ Externally Applied Voltage
- V₊ ≡ External Upper Threshold Voltage Level
- V₋ ≡ External Lower Threshold Voltage Level
- V_{IHC1} = Device* Input Voltage Clamp Level; Low Voltage DC Case
- V_{IHC2} = Low Voltage AC Case
- V_{IHC3} = High Voltage DC Case
- I_{IN} = Device Input Current
- V_{IN} = Device Input Voltage
- V_{TH+} = Device Upper Voltage Threshold Level
- V_{TH-} = Device Lower Voltage Threshold Level
- I_{TH+} = Device Upper Input Current Threshold Level
- I_{TH-} = Device Lower Input Current Threshold Level
- R_x = External Series Resistor for Selection of External Threshold Level
- R_p = External Parallel Resistor for Simultaneous Selection/Accuracy Improvement of External Threshold Voltage Levels
- I₊ = Total Input Current at Upper Threshold Level to External Resistor Network (R_x, R_p) and Device
- I_{p+} = Current in R_p at Upper Threshold Levels
- V_{peak} = Peak Externally Applied Voltage
- V_O = Output Voltage of Device

- V_{OL} = Output Low Voltage of Device
- V_{OH} = Output High Voltage of Device
- I_{OH} = Output High Leakage Current of Device
- I_{OL} = Output Low Sinking Current of Device
- I_{IH} = Input High Current of Driven Gate
- I_{IL} = Input Low current of Driven Gate
- V_{CC} = Positive Supply Voltage
- R_{IN} = Input Resistance of HCPL-3700
- V_{T+} ≡ Schmitt Trigger Upper Threshold Voltage of TTL Gate (7414)
- R_L = Output Pullup Resistance
- C_L = Output Filter Capacitance
- C = Input Filter Capacitor
- TH₊ = Upper Threshold Level
- TH₋ = Lower Threshold Level
- P_{R_x} = Power Dissipation in R_x
- P_{IN} = Power Dissipation in HCPL-3700 Input IC
- PA = Input Signal Port to P.I.A.
- t₊ = Turn On Time
- t₋ = Turn Off Time
- T = Period of Waveform
- C_p = Similar to R_p

*Device = HCPL-3700

