

Lightwave measurements using the HP 8510

Product Note 8510-15

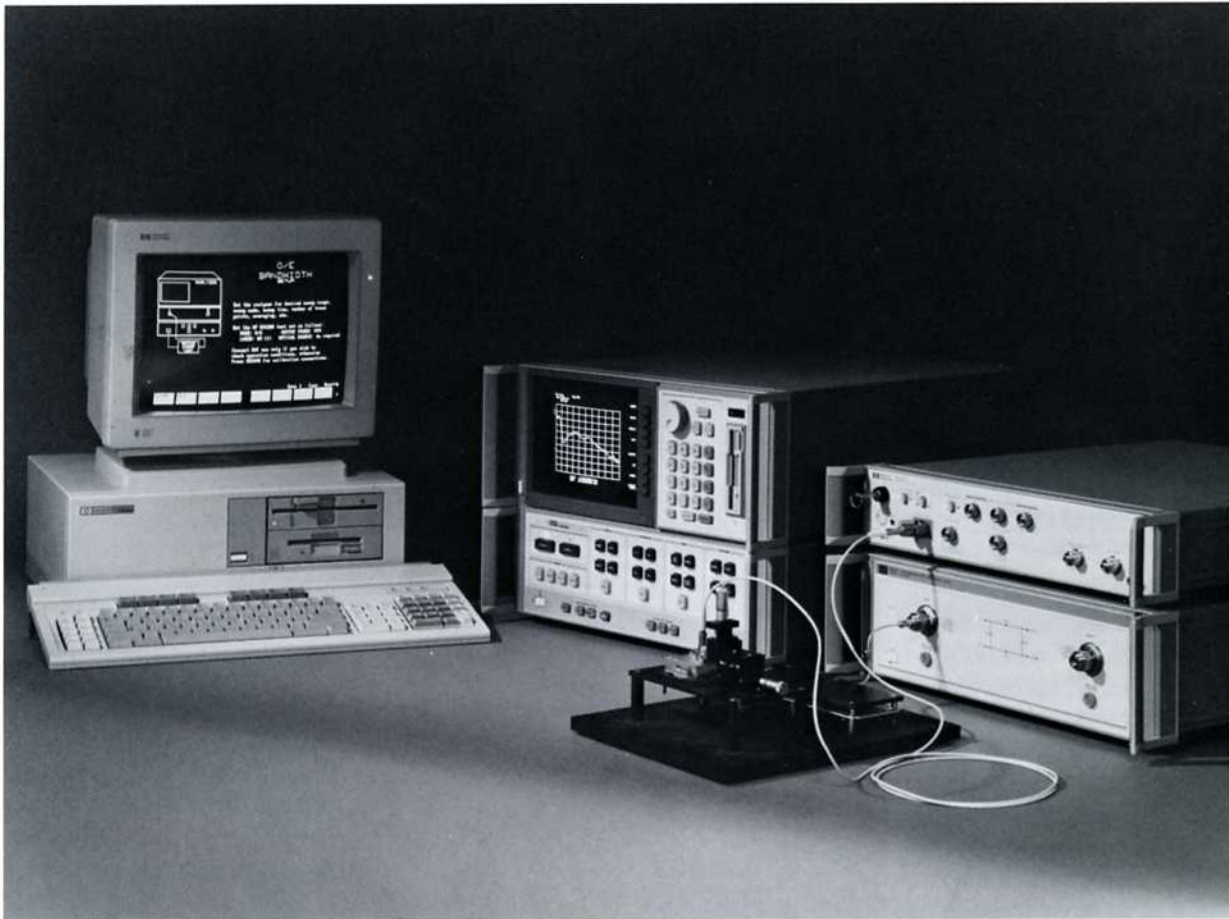

Introduction

As modulation rates of lightwave or fiber optic systems extend into the RF and microwave frequency ranges, lightwave component analysis is a natural extension of microwave network analysis. Many of the problems that occur in microwave components and systems are also encountered in high-speed lightwave systems. For instance, laser modulation characteristics will vary depending on the magnitude of back reflected light. Maximum data rates are directly dependent on device modulation bandwidth. Conversion efficiency or responsivity is degraded when signal reflections occur, both in the electrical and optical domains. The ability to characterize individual components as a function of modulation frequency provides valuable insight into how the building blocks of a system contribute to overall system performance. In addition, calibrated instrumentation allows for the accurate characterization of devices independent of the test system.

With the addition of an HP 83420 Lightwave Test Set and an external controller, a microwave network analyzer such as the HP 8510 (or HP 8720) can be configured to make calibrated measurements of optical and opto-electronic devices in a manner similar to network measurements of microwave components. The microwave network analyzer can then function as a lightwave component analyzer, similar to the HP 8703. (See page 9)

The concept of lightwave component analysis is straightforward. Measurements are made of the transmission and reflection characteristics of lightwave components using techniques similar to those used in characterizing microwave components. A precise electrical (signal generator) or optical (laser) source is used to stimulate the compon-

ent under test and a very accurate optical or electrical receiver measures the transmitted (or reflected) signal. Since characterization over a range of modulation frequencies is required, the electrical signal (used to modulate the optical stimulus, or as a stimulus itself) is normally swept over the desired bandwidth.

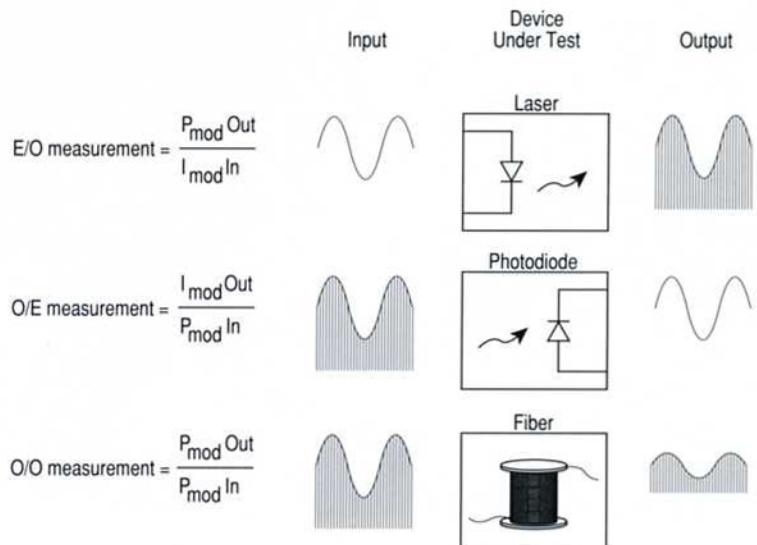
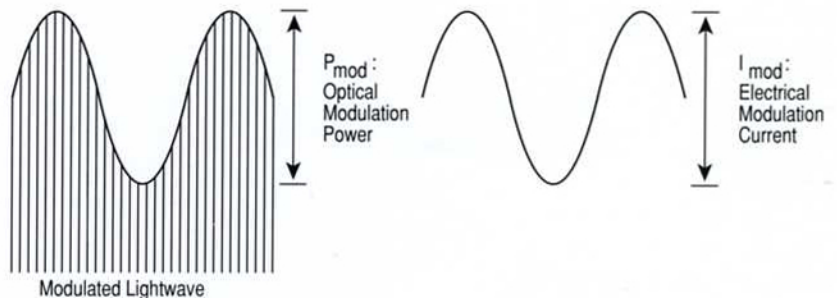

Example Measurements

Evaluating lightwave components as a function of modulation bandwidth yields important information regarding how a device will behave in a high-speed system. It is also important to optimize the energy flow to and from devices for maximum efficiency and signal-to-noise ratios. The following discusses some specific measurements that can be made.

The addition of the lightwave test set and an external controller will allow you to make the following measurements on optical and opto-electronic components:

- Modulation bandwidth, frequency response and responsivity
- Step or impulse response¹
- Modulation group delay and differential phase
- Distance-time response¹
- Optical return loss and reflections (optical reflectometry¹)

This note describes the configuration and operating theory of the HP 8510/83420 lightwave test system. Example measurements and calibration procedures will be discussed.

Measurements on E/O devices

Figure 1 shows the modulation bandwidth of a laser transmitter measured on an HP 8510/HP 83420 system. The frequency response and bandwidth can be easily determined. In this case, the input stimulus to the laser is a swept microwave signal. The laser output signal drives the test set lightwave receiver. (The details of lightwave measurement calibration will be discussed later.) Displayed is the ratio of the laser's modulated optical output power to electrical input current. This is often referred to as "slope responsivity": the optical power change relative to a change in input current. Figure 2 shows the impulse response of the laser (using the optional time-domain capability of the network analyzer). This information can be used to determine how fast the laser can be modulated and the effective transducer gain, in either analog or digital applications.

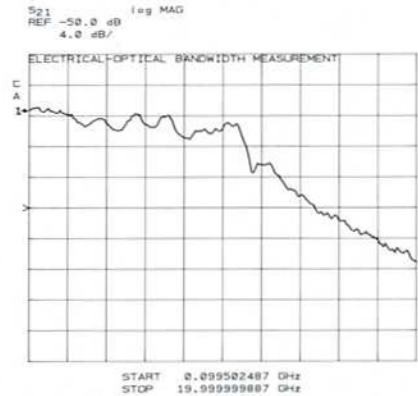

Figure 1.
Laser modulation bandwidth

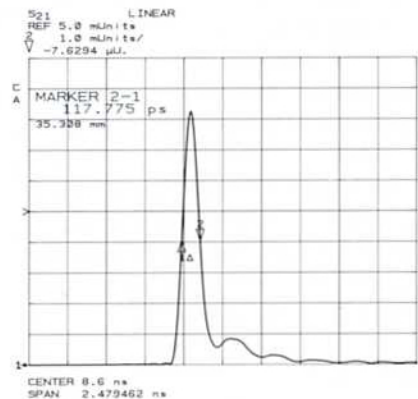

Figure 2.
Laser impulse response

¹Requires optional time-domain capability in the network analyzer.

Figures 3 and 4 show the input match of the laser both in return loss and impedance, indicating how well the laser receives the electrical modulating signal. This data can be used with electrical impedance matching techniques to optimize electrical signal transfer. Similar measurements in the optical domain can be made to characterize light reflections off of the laser, such as an optical return loss measurement.

Measurements on O/E devices

Figure 5 shows the modulation responsivity of a photodiode. It is very similar to the laser frequency response measurement, except in this case the input stimulus is a swept modulated lightwave. Displayed is the ratio of swept modulation electrical current to input optical modulation power. Input optical match and output electrical match can be characterized similar to methods discussed above for the laser.

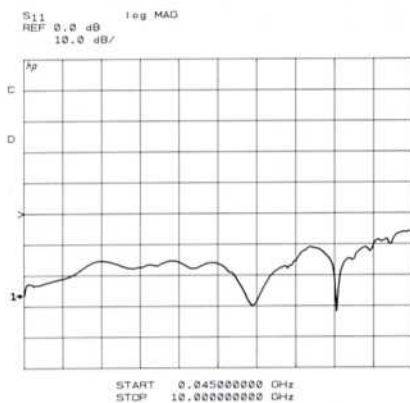

Figure 3. Laser input impedance: Return loss

Optical reflections

Signal reflections can lead to many problems in the optical domain. To eliminate reflections, they must be located and characterized. Individual reflections can be located with sub-millimeter accuracy while two reflections can be distinguished with separation as little as one centimeter. Figure 6 shows the reflections off of a photodiode assembly in the time (distance) domain. The first reflection is off of the GRIN lens. The second reflection, 13 millimeters away, is the photodiode itself. In comparing this technique to OTDR measurements, note that the time/distance resolution is extremely high (due to the 20 GHz measurement bandwidth), there is no dead zone, and the dynamic range is increased. Unlike an OTDR, backscatter is not displayed.

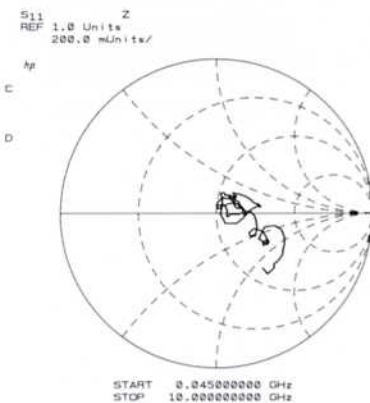

Figure 4. Laser input impedance: Smith chart

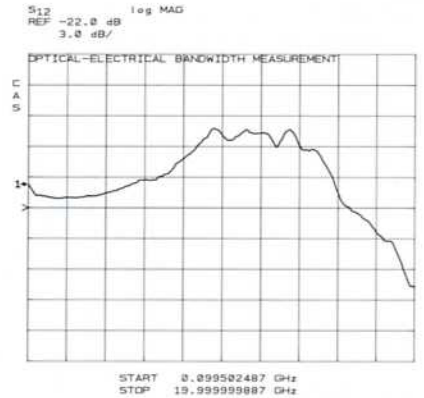

Figure 5. Photodiode modulation bandwidth

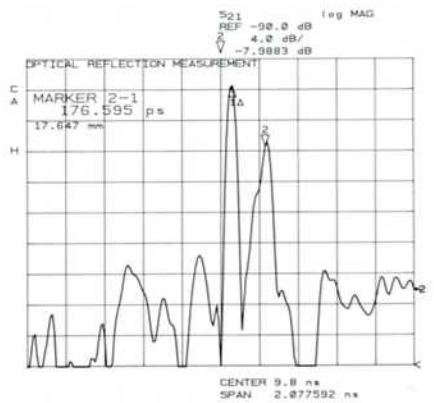

Figure 6. Photodiode reflection measurement: Time domain

Making Accurate Lightwave Component Measurements

The processes to make these measurements are simple. To demonstrate this, consider the example of measuring a photodiode's modulation bandwidth. The first step is to perform a measurement calibration to remove the response effects due to the lightwave source and the microwave receiver used in the measurement. During this user calibration, the full optical path is measured including the test set optical source, optical fiber, test set lightwave receiver, and any switches, attenuators or connectors. The lightwave receiver within the lightwave test set is the only portion of the calibration measurement which will not be in the actual measurement of the photodiode. The response of the test set lightwave receiver is determined at the factory and stored as part of the controller software. (Thus the software for each HP 83420 is unique to that test set). The controller then modifies the user calibration data so that when it is incorporated into the actual measurement of the photodiode, only the response of the photodiode under test remains.

Similar techniques are used for measuring E/O and O/O devices. The electrical and optical sources, receivers, and paths are all characterized during the user calibration. (See following page "Lightwave Measurement Calibration"). Once the calibration has been completed and loaded, the network analyzer is placed into local mode allowing front panel or automatic operation. The network analyzers' built-in capabilities, such as making measurements, formatting data, and producing hard copies, can now be used.

In addition to measurement calibration, good measurement techniques will enhance the repeatability and accuracy of lightwave component measurements. Just as in making microwave measurements, connector cleanliness and care is vital for both electrical and optical measurements. Highly reflective devices can increase measurement uncertainty by changing how other components behave (such as light being reflected back into a laser) . Mismatch error will increase measurement uncertainty. Power levels should be set such that devices are operating linearly and yet maintain as high a signal-to-noise ratio as possible.

Lightwave Measurement Calibration

Lightwave component analysis, similar to microwave component analysis, is based upon making ratio measurements. For example, the gain of a microwave amplifier is the ratio of output to input power. Similarly, laser slope responsivity is the ratio of optical modulation power to input electrical modulation current. Photodiode responsivity is the ratio of electrical modulation current to input optical modulation power. Optical reflection measurements consist of the ratio of reflected to input optical power. Consequently, calibration techniques used in lightwave component analysis have many similarities to those used in microwave network analysis.

Reflection measurement calibrations

The similarities in calibration techniques are readily apparent when making reflection measurements. Calibration for microwave reflection measurements consists of measuring known standards such as open and short circuits which provide 100% signal reflection and known phase. An analogous process is used with optical reflections. Instead of open or short circuits, a known optical reflection is used. A polished mirror (100% reflection) could be used, but typically a Fresnel reflection (cleaved, polished fiber end) providing a 3.5% (14.56 dB) reflection is the standard. Distance (phase) is set to zero at the plane of the reflection.

Transmission measurement calibration

Calibration for a ratio measurement becomes more complex when one signal is optical and the other is electrical. For optical to electrical or optical to optical measurements, the source of modulated light must be characterized and removed from the measurement. For an electrical to optical measurement, the instrumentation must be capable of removing the response of its internal lightwave receiver. The phase and magnitude response of the optical receiver is calibrated at the factory. The test set receiver then becomes a reference standard for both O/E and E/O calibrations. The receiver calibration data is part of the controller software.

Consequently, measurement calibration of the optical source and receiver is achieved by simply connecting a through fiber from source to receiver, similar to a response calibration performed for a microwave transmission measurement. The controller software uses the measurement calibration data in conjunction with the factory calibration data to generate the appropriate calibration array for the network analyzer.

System overview and operation

When characterizing lightwave components, there are several potential sources of measurement error. The response of the device being measured can be difficult to isolate from the laser and photodiode portions of the test system. The device being tested may also interact unfavorably with the test set laser or photodiode leading to incorrect or unrepeatable measurements. To overcome these potential problems, several key hardware features have been built into the lightwave test set to enhance its measurement capability. Built into the HP 83420 is an optical source consisting of a CW Fabry-Perot laser (a DFB laser is optional), an optical isolator, polarization controller, and lithium niobate Mach-Zehnder external modulator (see Figure 7). The modulator allows optical modulation at rates up to 20 GHz. Internal leveling maintains the level of modulated optical power.

The isolator prevents back reflected light from altering the output characteristics of the laser and leading to inconsistent measurements. The laser temperature and modulator bias voltage are precisely controlled, even in standby mode, further enhancing the source stability. A wideband RF amplifier provides the necessary boost in RF power to drive

the modulator. The amplifier output can also be routed to the front panel for applications requiring high RF drive levels, such as modulating a laser. The optical receiver consists of a high-speed photodiode and wide-band amplifier. The photodiode is designed to be polarization insensitive, thus enhancing measurement repeatability.

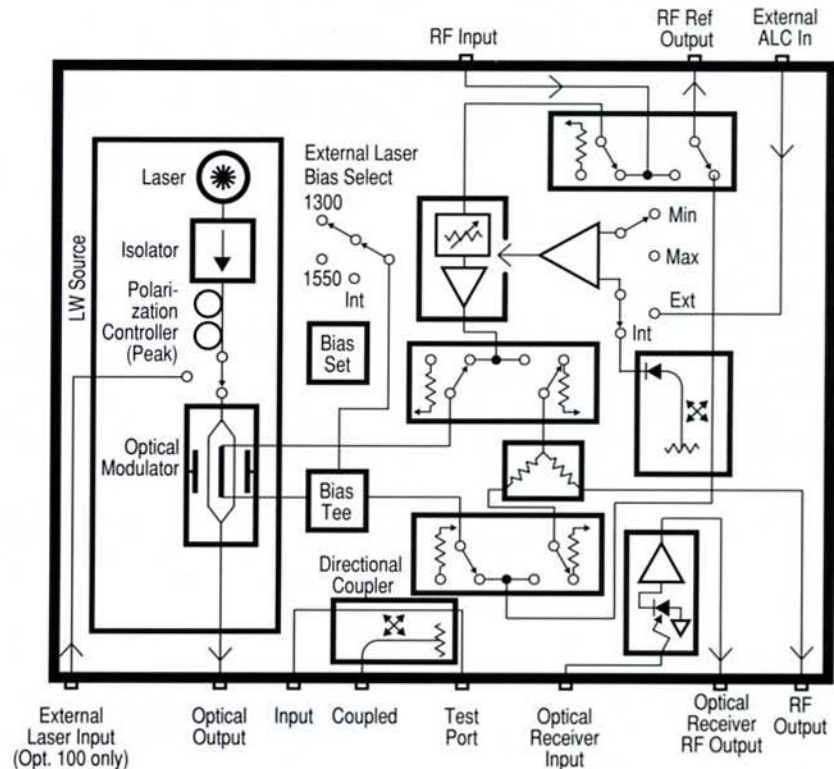

Figure 7.
HP 83420
Lightwave
test set
block diagram

Another key feature of the control software is the Guided Setup. The Guided Setup is a powerful user interface for the measurement system. This feature uses text and diagrams to lead the user through the various instrument settings, connections and calibrations required to make accurate measurements. Once the measurement has been configured and the calibration has been performed, the control program places the network analyzer in local mode, allowing the user to operate the network analyzer from the front panel or through the controller with user-generated software.

To add a lightwave test set to an existing network analyzer system, the RF source is connected to the lightwave test set (see Figure 7). The lightwave test set amplifies the signal (up to 20 dB) and then routes it to one of three locations in the lightwave test set depending on the type of measurement being performed: When measuring devices that require modulated light (such as photodiodes or fiber), the amplified RF is routed to the optical modulator. When measuring an electro-optical device (such as a laser), the amplified RF, at levels up to +12 dBm, is routed to the front panel of the lightwave test set to be used to drive the laser under test. When strictly electrical devices are measured, the lightwave test set is bypassed through an internal switch and routed to the microwave test set.

The network analyzer in this case is operated as if the lightwave test set were not present. There will be an approximate 1 dB drop in available power to the microwave test set due to the insertion loss of the RF switch in the lightwave test set. In all modes of operation, an RF signal is routed to the network analyzer to serve as a reference for phase locking. Note that the movement

of only two RF cables is necessary to modify an existing HP 8510 system: the RF source now passes through the HP 83420 and the response signal from the device under test is fed to the microwave test set.

The internal switching in the lightwave test set can be actuated manually at the front panel or through the system controller via a GPIO card.

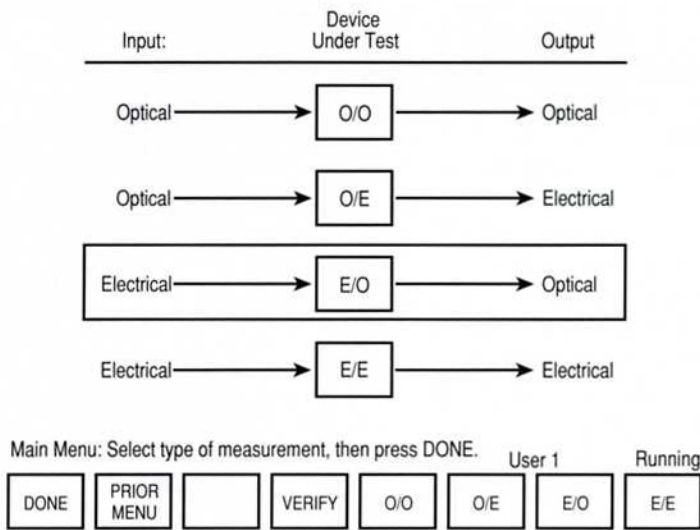

Figure 8. Guided setup: Measurement configuration.

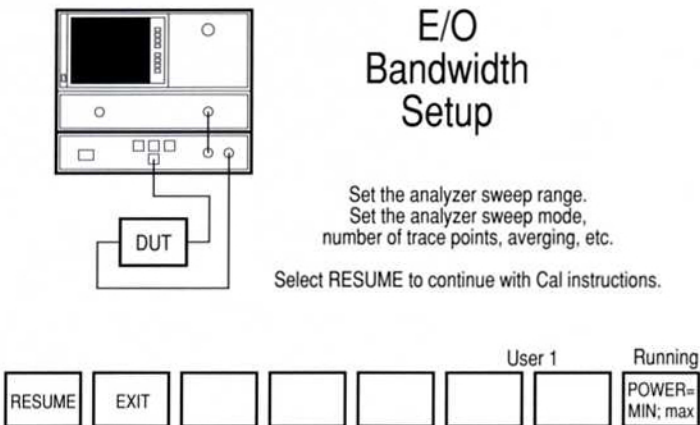

Figure 9. Guided setup: Measurement configuration

System equipment requirements

Figure 10 is a system configuration diagram showing the additional required connections for an HP 8510-based lightwave component analyzer system. The basic test setup includes an HP 8510 network analyzer system, system controller and software, and the HP 83420 lightwave test set. The 45 MHz to 20 GHz frequency range of the HP 83420 will set the limits of calibrated operation. Figure 11 is the configuration diagram for an HP 8720 option H80 system.

The RF source is controlled by the network analyzer, while the network analyzer and lightwave test set are controlled by the system controller and system software.

The system controller must be capable of running BASIC 5.0 (or above) and have 2 Mbytes of memory (to accommodate both the controller software and BASIC). A GPIO card is included with the HP 83420 to automatically control the switching in the lightwave test set.

The standard wavelength of operation is 1300 nm; 1550 nm is also available. For multiple wavelength testing, HP 83420 Option 100 allows the use of a second laser source. Fully calibrated measurements are available at both 1300 and 1550 nm wavelengths.

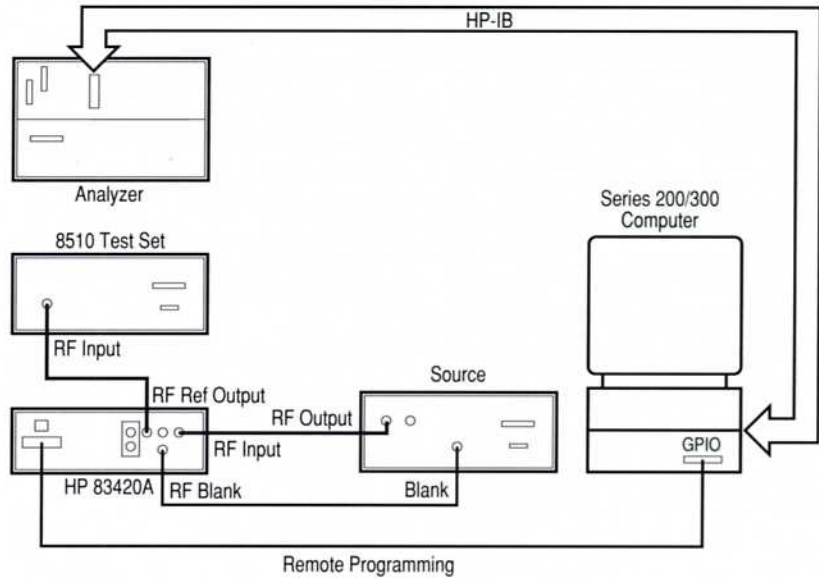

Figure 10.
HP 8510/HP
83420
Configuration
diagram

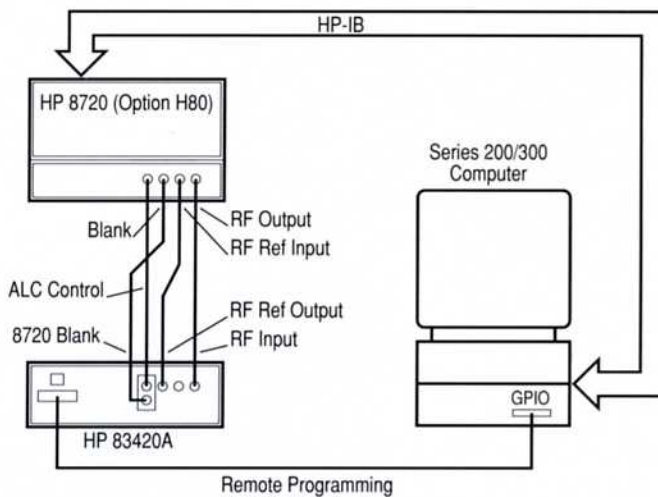

Figure 11.
HP 8720 H80/
HP 83420
Configuration
diagram

Configuring a System

HP 83420 lightwave component analysis system:

HP 83420 Lightwave Test Set (includes the system controller software and a GPIO card for HP series 200/300 computers)

Network Analyzer

HP 8510 (with 3.12 firmware or higher, 5.11 or higher recommended)

HP 8720 or HP 8719 with option H80 (recommend 2.0 or higher firmware)

Microwave Test Sets

HP 8514, HP 8515, or HP 8516 (usable to 20 GHz)

(HP 8720/19 use an internal test set)

Microwave Sources

HP 8340, HP 8341, or HP 8360 Series Synthesized Sweepers

(HP 8720/19 use an internal source)

System Controller

HP Series 200 or 300 computer (except HP 9826)

2 Megabytes of memory (to load both BASIC and the controller program)
BASIC 5.0 (or higher)

or

IBM-compatible computer with HP 82300C BASIC Language Processor card (with HP 83205 to provide 0.5 Megabytes of additional memory)

Recommended for IBM compatible, but not required:

HP 82306 GPIO card (to allow automatic control of the lightwave test set switches)

The lightwave measurement capability and accuracy of the HP 8510 network analyzer/lightwave test set system is very similar to the completely integrated HP 8703 lightwave component analyzer. The HP 8703 optical hardware is mated with the microwave hardware to form a single instrument. When measuring E/O or O/E device types, this allows an enhanced calibration technique to compensate for measurement errors due to electrical mismatch. An optional optical receiver is available to allow for simultaneous optical transmission and

reflection measurements. The internal operation is designed around and dedicated to making both lightwave and microwave measurements. An external controller is not required.

(See Lightwave Component Analyzers P/N 5958-0394, and 5958-0391, and the HP 8703A Lightwave Component Analyzer Technical Data P/N 5952-1754).

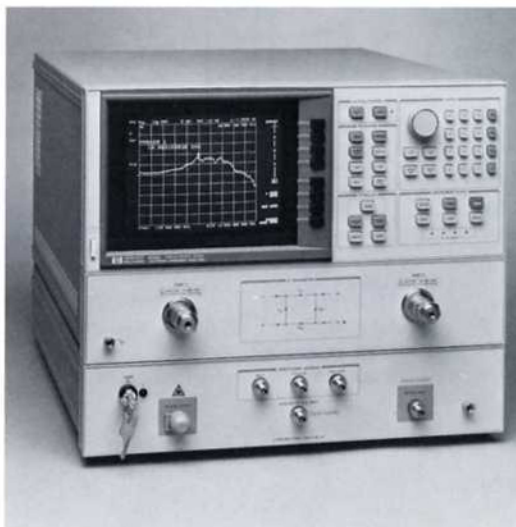

Performance overview

The following statistics characterize typical performance of the HP 8510 and HP 83420 system. The capability is similar to the HP 8703 Lightwave Component Analyzer. Refer to HP document 5952-1754 "HP 8703A Lightwave Component Analyzer Technical Data".

System dynamic range values are listed in terms of responsivity in dBe^1 or dBo^2 . Responsivity measurement limits are in turn set by the gains, losses, and signal level limitations of both the lightwave and microwave test sets. (Refer to product specific technical data for detailed information). Examples: In an O/E measurement, the HP 83420 will typically output less than 50 μW p-p modulation power when in minimum power mode. Using this power to drive an O/E device with a responsivity of 50 dBe (316 A/W) will produce an output power of 2 dBm in a 50 Ohm system. This approaches the maximum level appropriate for most microwave test sets. Similarly, the RF output power of the HP 83420 (in minimum mode) is typically 0 dBm , while its lightwave receiver has a typical responsivity of 30 dBe . An E/O device with -28 dBe responsivity will produce about 2 dBm at the microwave test set.

If test devices have responsivities exceeding these dynamic range limitations, optical or electrical attenuation can be added to reduce signal levels. Actual signal levels can be measured to make sure the test system is not overdriven.

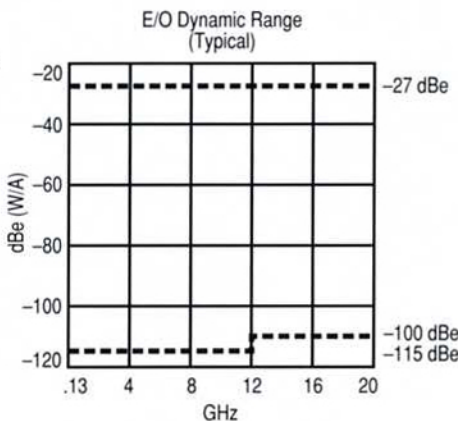
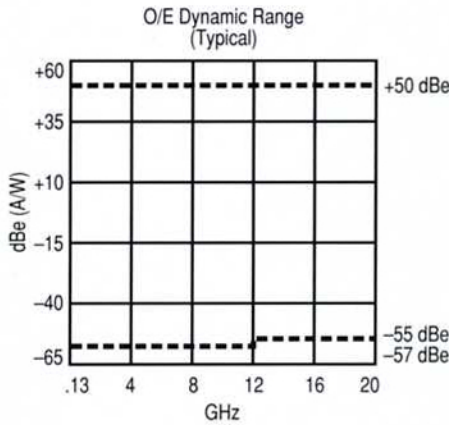
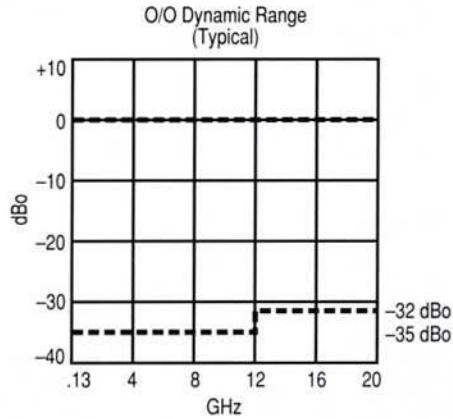

Additional reference literature

HP RF and Microwave Symposium Papers:

Lightwave Measurements to 20 GHz with your Microwave Network Analyzer HP Lit. P/N 5952-2767

Technical Innovations for the Design of a New 20 GHz Lightwave Component Analyzer HP Lit. PN 5952-2389

High-Speed Lightwave Component Analysis HP Lit. P/N 5958-0399

High-speed Optical Modulator for Lightwave Instrument Applications HP Lit. P/N 5952-2762

Accuracy Considerations and Error Correction Techniques for Lightwave Component Analysis HP Lit. P/N 5952-3204

Optical Measurements Based on RF Modulation Techniques. To be printed in the IEEE Transactions on Instrumentation and Measurements, Dec. 1990

¹ For optical to electrical devices, "dBe" = $20 \log [(\Delta\text{current (A p-p)})/(\Delta\text{optical power (W p-p)})/(1 \text{ A/W})]$
For electrical to optical devices, "dBe" = $20 \log [(\Delta\text{optical power (W p-p)})/(\Delta\text{current (A p-p)})/(1 \text{ W/A})]$

² For optical to optical devices "dBo" = $10 \log (\text{output power W p-p}/\text{input power W p-p})$

**For more information, call
your local HP sales office
listed in your telephone
directory or an HP regional
office listed below for the
location of your nearest sales
office.**

United States:

Hewlett-Packard Company
4 Choke Cherry Road
Rockville, MD 20850
(301) 670 4300

Hewlett-Packard Company
5201 Tollview Drive
Rolling Meadows, IL 60008
(708) 255 9800

Hewlett-Packard Company
5161 Lankershim Blvd.
No. Hollywood, CA 91601
(818) 505 5600

Hewlett-Packard Company
2015 South Park Place
Atlanta, GA 30339
(404) 955 1500

Canada:

Hewlett-Packard Ltd.
6877 Goreway Drive
Mississauga, Ontario L4V 1M8
(416) 678 9430

Japan:

Yokogawa-Hewlett-Packard Ltd.
15-7, Nishi Shinjuku 4 Chome
Shinjuku-ku, Tokyo 160, Japan
(03) 5371 1351

Latin America:

Hewlett-Packard
Latin American Region Headquarters
Monte Pelvoux No. 111
Lomas de Chapultepec
11000 Mexico, D.F. Mexico
(525) 202 0155

Australia/New Zealand:

Hewlett-Packard Australia Ltd.
31-41 Joseph Street
Blackburn, Victoria 3130
Melbourne, Australia
(03) 895 2895

Far East:

Hewlett-Packard Asia Ltd.
22/F Bond Centre, West Tower
89 Queensway, Central, Hong Kong
(852) 848 7777

South Africa:

HiPerformance Systems
(011) 802 5111

Middle East and Africa:

Geneva-Switzerland
41/22 780 7111

Israel:

Computation and Measurement
Systems (CMS) Ltd.
(03) 5380 333

**In Europe, please call your
local HP sales office or
representative:**

Austria:

(0222) 2500-0

**Central Europe, USSR, and
Yugoslavia:**

(0222) 2500-0

Belgium and Luxembourg:

(02) 761 31 11

Denmark:

(42) 81 66 40

Finland:

(90) 88 721

France:

(1) 69 82 60 60

Germany:

(06172) 16 0

Greece:

(01) 68 28 811

Iceland:

(91) 67 10 00

Ireland:

(01) 88 33 99

Italy:

(02) 95 300 134

Netherlands:

(020) 547 6669

Norway:

(02) 24 60 90

Spain:

900 123 123

Sweden:

(08) 750 20 00

Switzerland:

(057) 31 21 11 (Head office)
(022) 780 41 11 (Suisse Romande)
(046) 05 15 05 (Customer Information
Center)

Turkey:

175 29 70

U.K.:

(0344) 369 369

European Headquarters:

Hewlett-Packard S.A.
150, Route du Nant d'Avril
1217 Meyrin 2
Geneva-Switzerland
41/22 780 8111