

Product Note 8510-8

Network Analysis

Applying the HP 8510B TRL calibration
for non-coaxial measurements

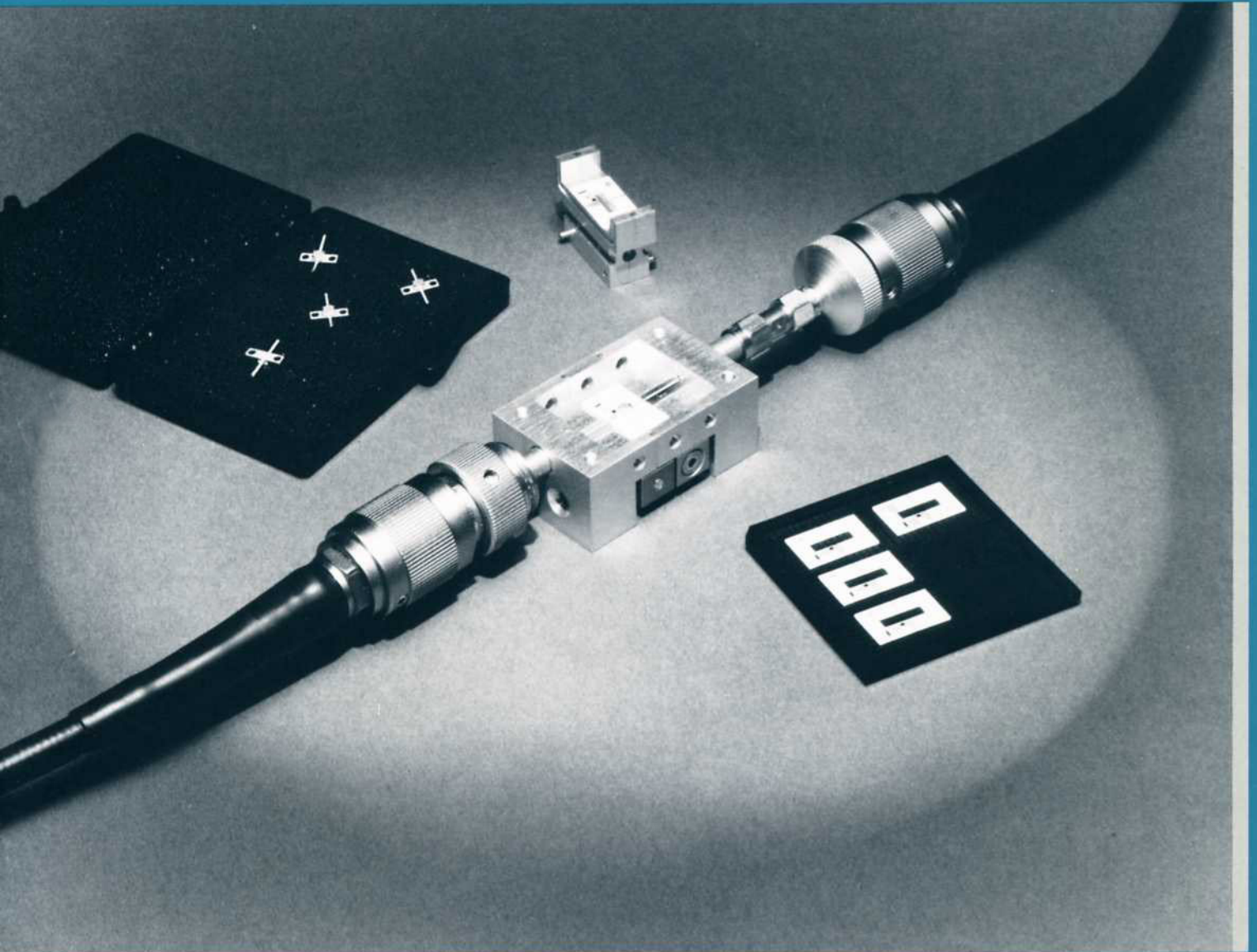

Introduction

This note describes how the HP 8510 network analyzer can be used to make error-corrected measurements in non-coaxial transmission media. Part 1 overviews the new HP 8510 TRL calibration method and how it overcomes some of the typical problems associated with making accurate non-coaxial measurements. Part 2 contains the guidelines for application of this new calibration method in a user-defined environment.

Part 1. TRL Calibration and Non-Coaxial Measurements

A major problem encountered when making network measurements in microstrip or other non-coaxial media is the need to separate the effects of the transmission medium (in which the device is embedded for testing) from the device characteristics. While it is desired to predict how a device will behave in the environment of its final application, it is difficult to measure this way. The accuracy of this measurement depends on the availability of quality calibration standards. Unlike coaxial measurements, a set of three distinct impedance standards are often impossible to produce for non-coaxial transmission media. For this reason, an alternative calibration approach may be useful for such applications.

The new TRL calibration technique relies only on the characteristic impedance of a short transmission line. From two sets of 2-port measurements that differ by this short length of transmission line and two reflection measurements, the full 12-term error model can be determined. Due to the simplicity of the calibration standards, TRL can be applied in dispersive transmission media such as microstrip, stripline and waveguide. With precision coaxial transmission lines, TRL currently provides the highest accuracy in coaxial measurements available today.

Many different names have been given to this overall approach — Self Calibration, Thru-Short-Delay¹, Thru-Reflect-Line², Line-Reflect-Line, etc.. These techniques are all variations on the same basic approach.

Measurement Example

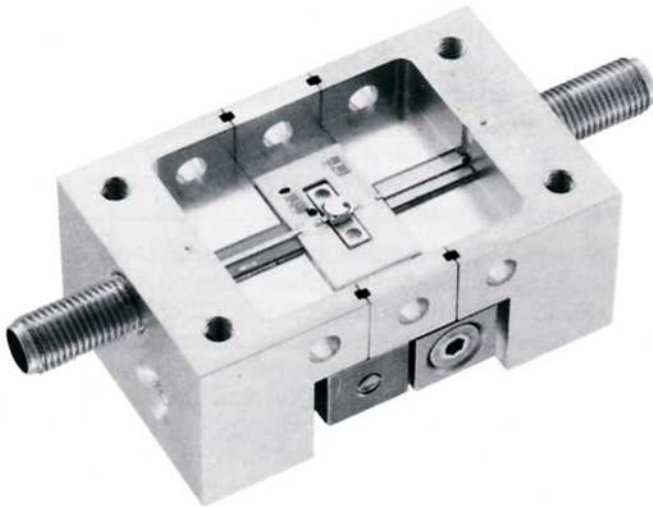

Figure 1. Microstrip test fixture.

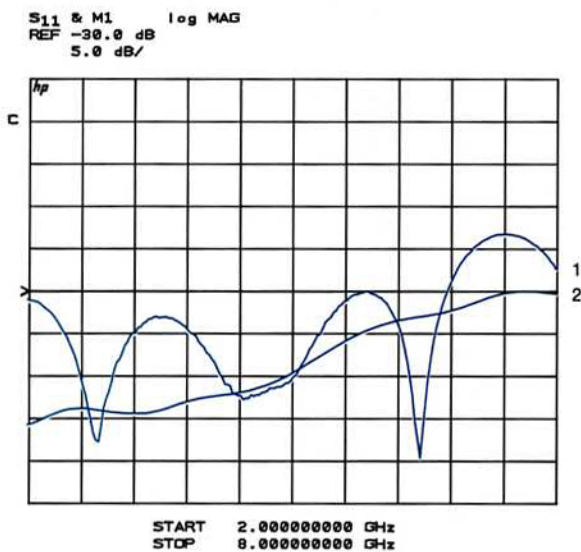

Figure 2. Example measurement of microstrip transmission line (1) calibrated at the coaxial ports of the fixture (2) calibrated in-fixture with TRL.

The microstrip fixture, shown in Figure 1, can be used to illustrate some of the typical problems associated with determining the parameters of a non-coaxial device. Among other effects, an impedance discontinuity occurs at the coaxial-to-microstrip launch and the signal is attenuated in the coaxial and microstrip portions of the fixture. These effects can significantly alter the measured data. Using the HP 8510B's TRL calibration and suitable standards, these systematic fixture effects can be characterized and removed.

For example, consider the measured response of a very simple network element, a 50 ohm microstrip transmission line. A comparison of the results from two different calibrations is shown here. First the network analyzer is calibrated at the coaxial ports of the test fixture using coaxial standards (open, short, load) and then inside the fixture using TRL standards.

Theoretically a matched transmission line would have very low return loss. With the coaxial calibration applied, the measured return loss of the line, shown in Figure 2 (top trace), is 20 dB at 7 GHz and exhibits significant mismatch ripple. Typical of most fixtures, the reflection at the coax-to-microstrip launch is larger than that at the device interface (for well-matched devices). Once the launch is characterized and removed using the in-fixture TRL calibration, the S-parameters of the transmission line can be measured directly. The lower trace in Figure 2 indicates a maximum return loss of 31 dB up to 8 GHz and does not exhibit any mismatch ripple.

Background

At microwave frequencies, systematic effects such as leakage, test port mismatch and frequency response will affect measured data. However, in a stable measurement environment these effects are repeatable and can be measured by the network analyzer. This process is called "measurement calibration."

During measurement calibration, a series of known devices (standards) are connected. The systematic effects are determined as the difference between the measured and known responses of the standards. Once characterized, these errors can be mathematically related by solving a signal flow graph. The 12-term error model, shown in Figure 3, includes all the significant systematic effects for the 2-port case.

The process of mathematically removing these systematic effects is called "error-correction". Under ideal conditions, with perfectly known standards, systematic effects would be completely characterized and removed. In conventional 2-port calibration, three known impedance references and a single transmission standard are required. The accuracy to which these standards are known establishes how well the systematic effects can be characterized. In fact, a well-established figure of merit for a calibrated system is the magnitude of the residual systematic effects. These residual effects are the portion of the uncorrected systematic error that remains because of imperfections in the calibration standards.

In non-coaxial measurements, it is more difficult to build impedance standards that are easily characterized. In microstrip, for example, short circuits are inductive, open circuits radiate energy and it is difficult to build a high quality purely resistive load. Because of these limitations, an alternative method for calibration in non-coaxial environments is needed that uses simple, realizable standards.

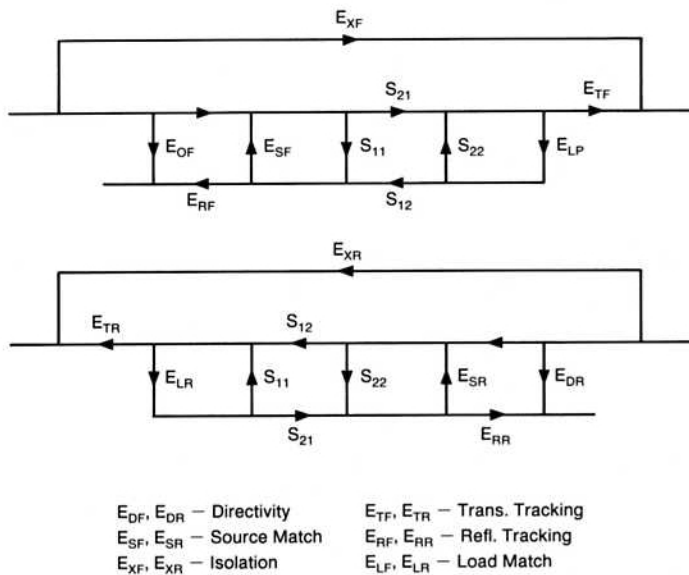

Figure 3. Two-port 12-term error model.

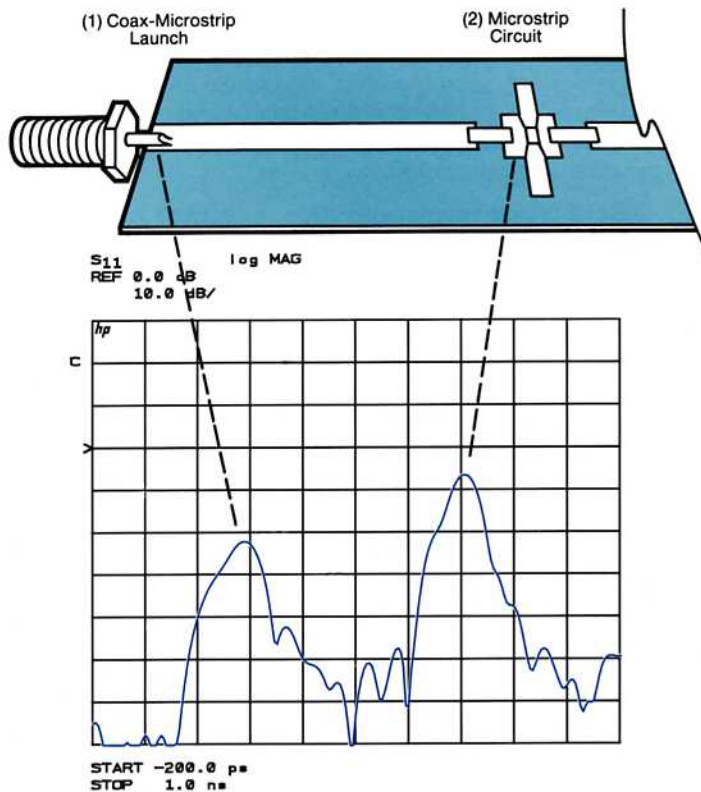

Figure 4. Time domain impulse response of an in-fixture device (1) coax/microstrip launch (2) test device.

HP 8510 TRL 2-Port Calibration

Typically, non-coaxial devices are mounted into coaxial test fixtures to be measured. The coaxial test fixture along with the device under test can now be connected to the network analyzer. Precision coaxial standards can be used to characterize the system up to the ports of the test fixture. At this point the problem has become that of devising a method to separate the effects of the test fixture from the response of the test device. A variety of techniques are employed. De-embedding the modeled response of a well-behaved fixture can provide reliable results when the fixture's characteristics are known. If a low loss, well-matched fixture can be constructed, simple normalization or port extension can be applied.

However, in the majority of cases the test fixture is not ideal and will exhibit impedance discontinuities and attenuation too complex to model conveniently. The time domain response of a typical microstrip fixture is shown in Figure 4. The impedance mismatch at the coaxial-to-microstrip launch causes some of the incident signal to be reflected. Time domain "gating" can be used to remove small reflections that are adequately spaced. The measured response of a microstrip device is also affected by the insertion loss magnitude and phase of the fixture. By calibrating at the device interface, the repeatable, systematic effects of the fixture (and the rest of the system) can be characterized.

THRU-REFLECT-LINE is an approach to 2-Port calibration that relies on transmission lines rather than a set of discrete impedance standards. Although its mathematical derivation is different than the conventional FULL 2-PORT, application of the technique results in the same 12-term error correction model.

There are three key advantages gained when using transmission lines as reference standards.

1. Transmission lines are among the simplest elements to realize in many non-coaxial media.
2. The impedance of transmission lines can be accurately determined from physical dimensions and materials.
3. Transmission lines have traditionally been used as standards and are well understood.

TRL refers to the three basic steps in the calibration process.

- THRU – connection of port 1 and port 2, directly or with a short length of transmission line
- REFLECT – connect identical one-port high reflection coefficient devices to each port
- LINE – insert a short length of transmission line between port 1 and 2 (different line lengths are required for the THRU and LINE)

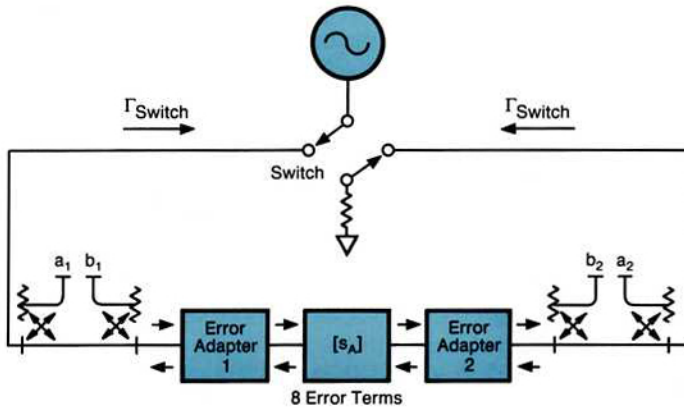
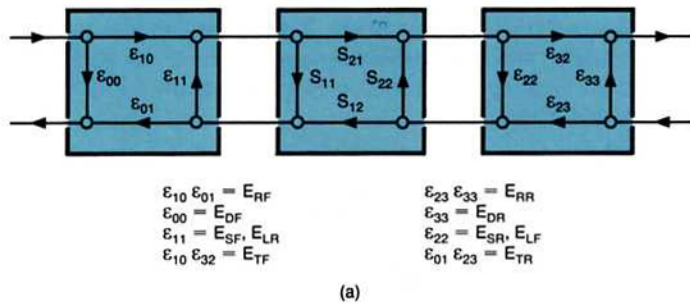
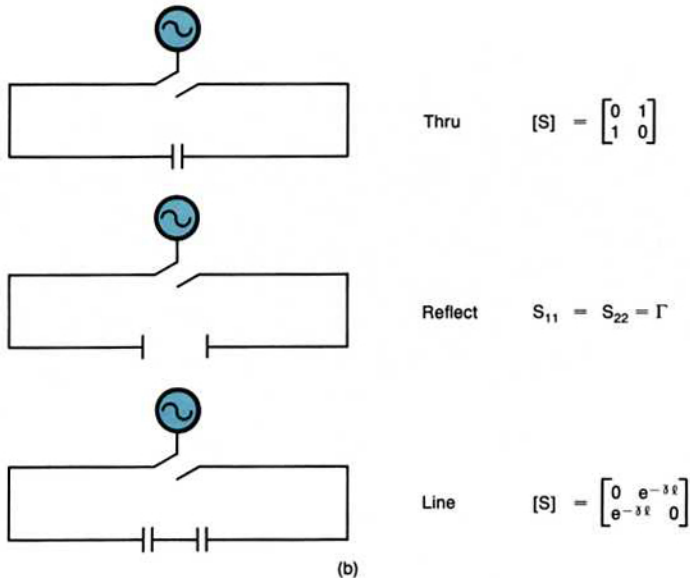

Figure 5. Functional block diagram for a 2-port error-corrected measurement system.



(a)



(b)

Figure 6. (a) 8-term TRL error model and generalized coefficients. (b) TRL procedure and assumed S-parameter values for each step.

While there is only one standard required in the TRL calibration process, compared to the conventional FULL 2-PORT method, its mathematical solution is not as simple. A total of 16 measurements is required to quantify the twelve unknowns. A complete mathematical solution for the TRL calibration will not be repeated here².

Figure 5 contains the block diagram for a simplified 2-port measurement system. Eight of the error terms are represented by the error adapters in the figure. These errors are characterized using the basic TRL calibration and are shown in Figure 6a. Although this error model has a slightly different topology than the 12-term model, the traditional error terms can be simply derived. For example, forward reflection tracking is simply the product of ϵ_{10} and ϵ_{01} . Notice that ϵ_{11} and ϵ_{22} serve as both the source and load match terms. To solve for these eight unknown error terms, eight linearly independent equations are required.

To compute the remaining four error terms, additional measurements are needed. These terms are solved separately and will be handled later.

The basic TRL calibration process is shown in Figure 6b. The THRU calibration step is the same as the Transmission step in the FULL 2-PORT method. The test ports are mated and then transmission frequency response and port match are measured in both directions (four measurements).

For the REFLECT step, the same highly reflective device (typically a short or open circuit) is connected to each test port and its reflection coefficient is measured (two measurements).

In the LINE step, a short transmission line is inserted and again frequency response and port match are measured in each direction (four measurements).

At this point ten measurements have been made resulting in ten equations. However, the basic TRL error model, shown in Figure 6a, has only eight unknowns. Because there are more measurements than unknowns, two constants defining the calibration devices can also be determined. In the TRL solution, the complex reflection coefficient of the REFLECT standard and the propagation constant of the LINE are determined. This is significant because now these characteristics do not have to be specified. In other calibration approaches the resultant measurement accuracy is dependent on how well all of the standards are known. When applying TRL, accuracy is not compromised even though these characteristics are unknown. The characteristic impedance of the transmission LINE becomes the measurement reference and therefore has to be known or assumed ideal.

Two additional steps are required to complete the calibration. Isolation is characterized in the same manner as the FULL 2-PORT calibration. Forward and reverse isolation is measured as the leakage from port 1 to port 2 with each port terminated.

Up to this point the solution for the error model assumes a perfectly balanced test system. The ϵ_{11} and ϵ_{22} terms represent both source and load match. However, in any switching test set, these terms are not equal. The RF switch, shown in Figure 5, presents a different terminating impedance as its position is changed between port 1 and port 2. Additional correction is provided by measuring the ratio of the incident signals (a_1 and a_2) during the THRU and LINE steps. Once the impedance of the switch is measured, it is used to modify the ϵ_{11} and ϵ_{22} error terms. ϵ_{11} is then modified to produce forward source match (E_{sf}) and reverse load match (E_{lr}). ϵ_{22} is modified to produce reverse source match (E_{sr}) and forward load match (E_{lf}).

Now, all twelve terms of the 2-port error model are determined. Also, the reflection coefficient of the REFLECT standard and the transmission response of the LINE can be measured directly.

The HP 8510B implementation of the TRL calibration has built-in flexibility which allows for adaptation to many different environments. The options that are available include:

1. Either zero-length or non-zero length THRU's may be used.
2. Any unknown highly reflective termination may be used as the REFLECT (i.e., open, short, offset short. . .).
3. Multiple LINES may be used to cover frequency spans of greater than 8:1.
4. The reference plane can be set relative to the THRU or the REFLECT.
5. Error-corrected measurements may be referenced to any real transmission line impedance (i.e., 50 ohms, 75 ohms, 10 ohms . . .).
6. TRL calibrations can be combined with a conventional (open-short-load) calibration for lower frequencies where transmission line standards are too long to be practical.
7. Can account for impedance variation versus frequency due to skin effect in coaxial transmission line.

This flexibility is designed to meet the demands for a variety of transmission media including coaxial, waveguide, microstrip, stripline and coplanar waveguide. This calibration method is not, however, limited to these environments. In the next section, aspects of fixture design are described and some typical measurement results are shown.

Elements of Fixture Design for TRL Calibration

The microstrip fixture, described here, illustrates some of the typical problems that may occur when applying TRL calibration. There are some key elements of fixture design that are required to apply this technique. This list is not intended to be exhaustive, but rather serve as a guide for user-specified fixtures.

Split-fixture design

The first requirement of the TRL calibration approach is the ability to insert calibration devices of different physical lengths. This fixture is a split-block design. The two halves of the fixture can be separated. The test and calibration devices are mounted to a center block which is inserted between the fixture halves.

Launch spacing

When calibrating in-fixture adequate separation between the coax/microstrip launchers is needed during the THRU and LINE measurements. As well as the dominant mode, higher order modes are generated at the launch. If there is not sufficient separation between the launchers, coupling of these higher order modes will produce unwanted variations during the error-corrected measurements. A minimum of two wavelengths is recommended.

Connection repeatability/ Stable environment

For accurate error correction, the system must be stable and the connection interface repeatable. The radiated electric fields around the microstrip lines in the fixture may change somewhat between calibration and measurement (due to the change in fixture separation during THRU, LINE and device measurement). Most of the microwave signal propagates through the dielectric between the surface conductor and the ground plane below the dielectric. However, as shown in Figure 7, some of the signal is supported by electric fields in the air above the substrate. As objects are introduced into the electric fields above the surface or when the fixture is separated, the propagation characteristics of the microstrip transmission line will change. These effects are nonsystematic and will not be removed through error-correction. To minimize this effect, the test environment should be the same during calibration and measurement. Further, the test environment should be similar to that of the final application. For example, if the cover of the final component will be 1 cm above the substrate, the fixture should also have the same type of cover.

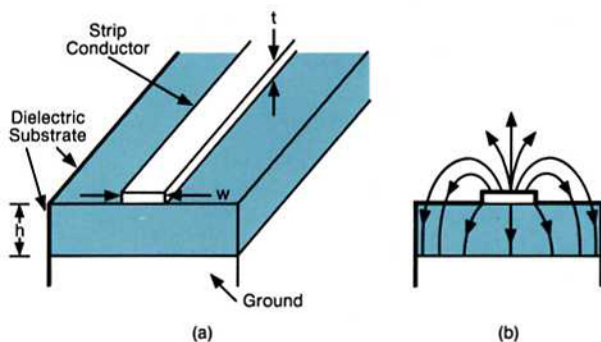

Figure 7. Microstrip transmission line geometry and electric fields.

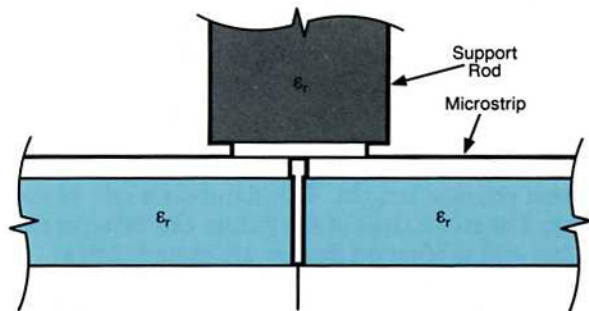

Figure 8. Expanded view of in-fixture microstrip interface showing contact mechanism.

The sidewalls of the measurement fixture may also act as a resonant cavity. The size of the cavity should be made small enough so that the resonant frequency is above the range of measurement and to prevent propagation of unwanted modes.

Connection to the calibration and test devices is provided by a thin piece of conductor on the end of a dielectric rod, as shown in figure 8. Its connection repeatability is about 40 dB. Good continuity in the ground plane and surface conductor must be provided. While making the connection, the dielectric rod will disturb the fields above the surface.

The thickness of the bridging conductor should be kept to a minimum. The impedance of the line is partially dependent on the total thickness of the surface conductor. As the bridging conductor is pressed into place, there is a small impedance discontinuity.

LINE impedance

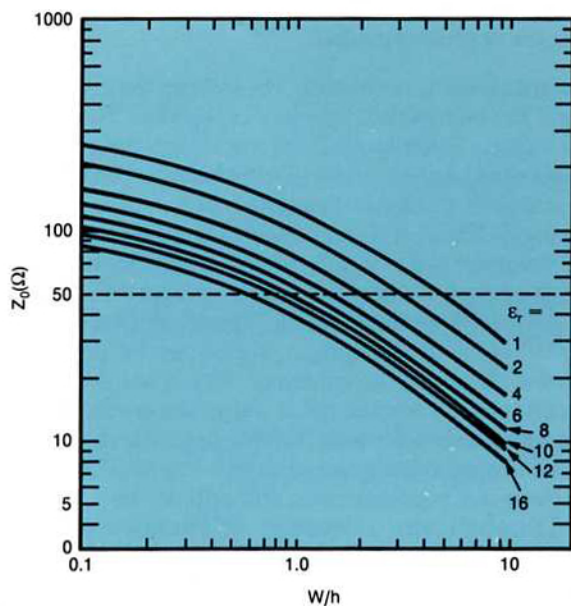

Figure 9. Characteristic impedance of microstrip line as a function of dielectric permittivity and dimensions — surface conductor width over dielectric thickness (W/h).³ (Copyright 1978 IEEE)

The 50 ohm transmission LINES are constructed on a sapphire substrate with deposited gold conductors. Characteristic impedance is a function of the transmission line dimensions and the substrate dielectric. These microstrip transmission lines have been produced to exhibit a 50 ohm characteristic impedance between 1 and 20 GHz.

Figure 9 shows the characteristic impedance of a microstrip line assuming negligible thickness of the surface conductor ($t/h < 0.005$).

Realizable standards

The steps of the TRL calibration method for this fixture are illustrated in Figure 10. This fixture provides a direct microstrip interface. The calibration plane will be established as the plane where the fixture halves meet. Test devices, mounted on center blocks, are connected directly at this calibration plane. A zero-length THRU is achieved by simply connecting the two halves of the fixture together.

The most simple REFLECT would be an open circuit. This is done by simply separating the fixture halves and is also shown. A short circuit could also be used. This would be necessary if, at the open circuit, significantly more energy was radiated than reflected. A short circuit could be made by contacting a shorting block in the center of the fixture.

The LINE standard is a short microstrip line inserted between the fixture halves. To construct this standard, the physical length must be computed. In dielectric-filled coaxial line, physical length can be found given the required electrical length and the relative permittivity of the dielectric. In microstrip, and other planar transmission media, propagation velocity is not uniform as a function of frequency. Complete microstrip models indicate that physical length and electrical length are related not only by the dielectric constant, but also the thickness of the dielectric, and the dimensions and conductivity of the surface and ground conductors.⁴

However, precise specification of the electrical length is not required in TRL, particularly when a zero-length THRU is used to set the reference plane. A quasi-TEM application can be applied. Quasi-TEM infers that the propagation velocity is essentially constant (non-dispersive) but offset by the effective dielectric constant. This effective dielectric constant is a function of the line's dimensions and material.

Let Propagation velocity = $c/\sqrt{\epsilon_{eff}}$
where: ϵ_{eff} is the effective relative dielectric constant.

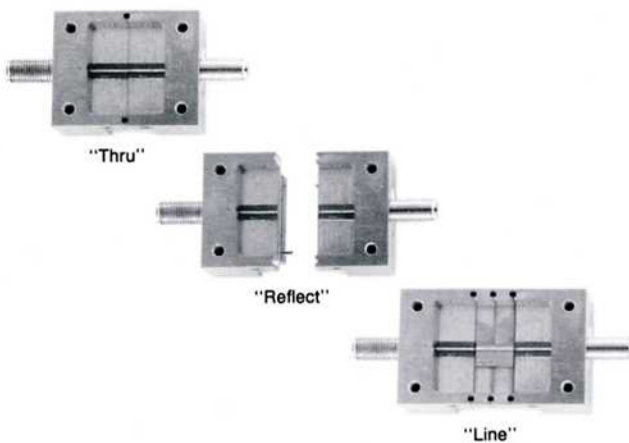

Figure 10. Calibration steps for a microstrip test fixture.

Measurement Examples

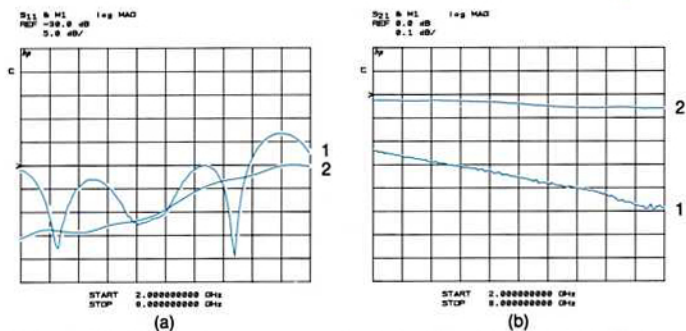

Figure 11. Example measurement (a) return loss of microstrip transmission line (b) insertion loss of a microstrip transmission line (1) calibrated at the coaxial ports of the fixture (2) calibrated in-fixture with TRL.

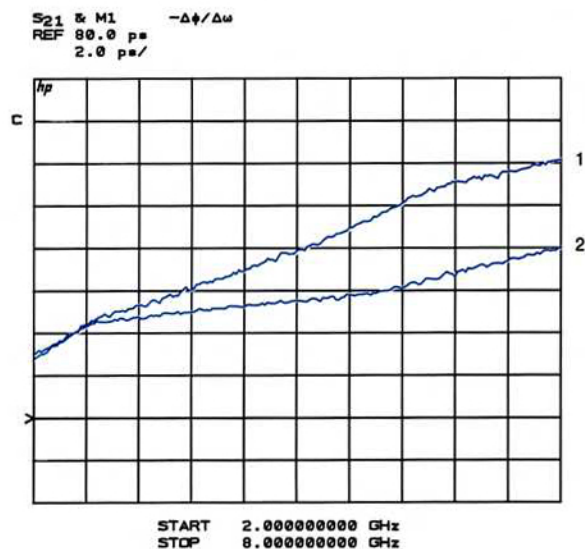

Figure 12. Example measurement of group delay for a microstrip transmission line (1) delay of 1 cm line, fixture length removed using 321 ps of linear electrical delay (2) delay of 1 cm line, fixture length removed using TRL.

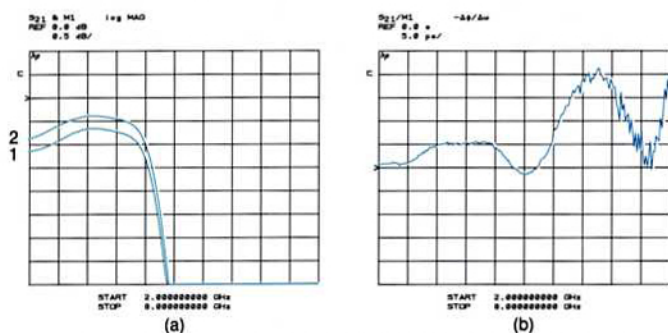

Figure 13. Example measurement of microstrip low-pass filter using TRL and coaxial calibration (a) passband insertion loss (1) calibrated at the coaxial ports of the fixture (2) calibrated in-fixture with TRL. (b) differential group delay, TRL compared to linear electrical delay compensation.

Typical measurement results for the microstrip test fixture and a simple microstrip PC board are shown here. First, measurements for the microstrip fixture will be shown.

The measured response of a 1 cm microstrip line is shown in Figures 2 and 11. To illustrate the benefits of direct in-fixture calibration, the results from two different calibration methods are shown.

The maximum reflection coefficient (S_{11}) of this line is about 23 dB when the system is calibrated at the coaxial ports of the fixture. After an in-fixture TRL calibration is performed, the maximum reflection coefficient is measured to be 30 dB. The reflection coefficient of the fixture itself is greater than the microstrip line. Only after the fixture's response has been removed is it possible to measure the response of the lower level reflection of the microstrip line. Ideally, the reflections at the microstrip interface would be very small. Most of this reflection is due to the small gap between the fixture body and the 1 cm line. As shown in Figure 11, the insertion loss of the line can also be measured directly, without the attenuation due to the fixture.

Precise measurement of electrical length or group delay in a dispersive environment like microstrip is typically difficult. Previous methods include using linear Electrical Delay to remove the linear phase shift in the fixture. However, since the fixture is dispersive (exhibits non-linear phase) the measured delay is not properly corrected. The precise group delay of the 1 cm line is attained with the TRL calibration method. The measured delay of the line is shown in Figure 12, comparing TRL correction to the linear correction. There is a 4 picosecond error when linear correction is applied, which is about 5% of the total delay.

Figure 13a shows the measurement of a 5 GHz Low pass Microstrip Filter. The measured passband attenuation is 0.3 dB less when the effects of the fixture are removed. Dispersion in the test fixture will also limit accurate characterization of the filter's delay as shown in the previous example. Group delay variation between the calibration methods is shown in Figure 13b.

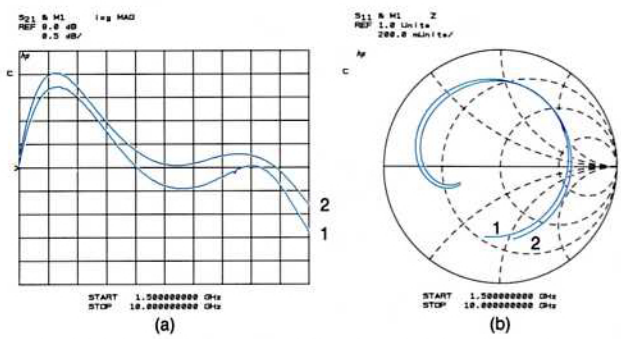

Figure 14. Example gain and impedance measurements of a microcircuit amplifier (a) amplifier gain (b) complex input impedance. (1) calibrated at the coaxial ports of the fixture (2) calibrated in-fixture with TRL.

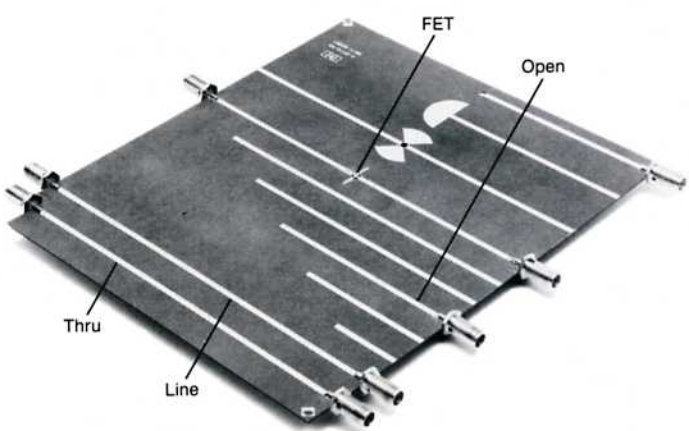

Figure 15. Microstrip PC board as a test fixture including separate transmission lines as the THRU and LINE, an open circuit and a test line for insertion of a test device.

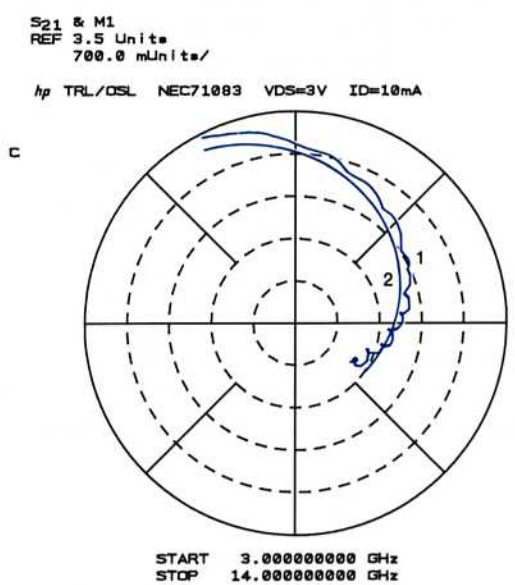

Figure 16. Example measurement of a linear FET on the microstrip PC board compared to measurement in a de-embedded test fixture (HP 85041A). (1) de-embedded measurement (2) TRL calibration using PC board standards.

Figure 14 shows the measurement of a 2 to 8 GHz Microstrip Amplifier. Gain and complex impedance measurements are shown using both in-fixture TRL and coaxial calibration methods. Simple amplifier circuits like this one are typically cascaded with other amplifier gain stages or matching/filtering stages. It is important that precise complex impedance, delay and available gain data are provided to predict how these various stages will interact. Using a direct microstrip calibration, the performance of this amplifier is now characterized for the 50 ohm substrate of the system component that it will be used in. These measurements show that available gain is as much as 0.4 dB higher when measured at the microstrip interface. Matching is typically achieved with transmission line structures. Accurate complex impedance is required to determine the appropriate length of line to conjugately match that stage.

Another example of a very simple noncoaxial environment is shown in Figure 15, a microstrip PC board. Though this is hardly a precision test environment and not recommended for general use, it is shown that TRL calibration can be used to make a reasonable measurement. A packaged stripline transistor is mounted into the center of the board. Coaxial connectors are soldered to the ends each of the lines. To calibrate, lines of different length must be used. Two lines are located at the top of this microstrip board. In the center is a microstrip open. The accuracy of this method will be compromised by the difference in response of the various lines. The difference in these lines can be evaluated by comparing the gated response of each launch. These launches are repeatable within 10 dB.

S_{11} and S_{21} measurements of a linear microwave FET are shown in Figure 16. For comparison, the FET was also measured in a well-characterized stripline test fixture. There is reasonable agreement in relative magnitude and phase for both S_{21} and S_{11} . There are small resonances in the measured data, when the TRL microstrip standards are used, but these should be expected due to the variation between the calibration lines and the line used for measurement.

In conclusion, the HP 8510 TRL calibration method has utility for a variety of non-coaxial environments and is certainly not limited to those described here.

Part 2. Implementing the TRL Calibration Method

This section describes the basic requirements and operational procedures for implementing the HP 8510B's TRL calibration method in a user-specified environment.

This process will be considered in four steps.

1. Selecting standards appropriate for the application that meet the basic requirements of the TRL technique.
2. Defining these standards for use with the HP 8510B by modification of the internal calibration kit registers.
3. Performing the calibration.
4. Checking the performance.

Selecting TRL Standards

Table 1 details the requirements of the TRL calibration standards. When building a set of standards for a user-defined environment, the requirements for each of these standard types must be satisfied.

Table 1. Requirements for TRL standards.

Standard	Requirements
REFLECT	Reflection coefficient Γ magnitude (optimally 1.0) need not be known Phase of Γ must be known within $\pm 1/4$ wavelength ¹ Must be the same Γ on both ports May be used to set the reference plane if the phase response of the REFLECT is well-known and specified
Zero Length THRU	S_{21} and S_{12} are defined equal to 1 at 0 degrees (typically used to set the reference plane) S_{11} and S_{22} are defined equal to zero ²
Non-Zero Length THRU	Characteristic impedance Z_0 of the THRU and LINE must be the same Attenuation of the THRU need not be known Insertion phase or electrical length must be specified if the THRU is used to set the reference plane ³
LINE	Z_0 of the LINE establishes the reference impedance after error correction is applied ⁴ Insertion phase of the LINE must never be the same as that of the THRU (zero or non-zero length) ⁵ Optimal LINE length is $1/4$ wavelength or 90 degrees relative to the THRU at the center frequency ⁶ Useable bandwidth of a single THRU/LINE pair is 8:1 (frequency span/start frequency) Multiple THRU/LINE pairs (Z_0 assumed identical) can be used to extend the bandwidth to the extent transmission lines are realizable Attenuation of the LINE need not be known Insertion phase or electrical length need only be specified within $1/4$ wavelength

1. The phase response need only be specified within a $1/4$ wavelength ± 90 degrees either way. During computation of the error model, the root choice in the solution of a quadratic equation is made based on the reflection data. An error in definition would show up as a 180 degree error in the measured phase.
2. A zero-length THRU has no loss and has no characteristic impedance.
3. If a non-zero-length THRU is used but specified to have zero delay, the reference plane will be established in the middle of the THRU. When the Z_0 of the THRU and LINE are not the same, the average impedance is used.
4. S_{11} and S_{22} of the LINE are also defined to be zero. With this assumption, the system impedance is set to the characteristic impedance of the LINE. If the Z_0 is known but not the desired value, the impedance of the LINE can be specified when defining the calibration standards.
5. The insertion phase difference between the THRU and LINE must be between (20 and 160 degrees) $\pm n \times 180$ degrees. Measurement uncertainty will increase significantly when the insertion phase nears 0 or an integer multiple of 180 degrees.
6. The optimal length of a LINE is $1/4$ wavelength or 90 degrees of insertion phase in the middle of the desired frequency span. However, the insertion phase of the $1/4$ wavelength LINE will vary with frequency.

$$\text{Phase (degrees)} = (360 \times \text{frequency} \times \text{electrical length})/c$$

This expression can be rearranged to solve for the electrical length of a $1/4$ wavelength at a center frequency.

$$\text{Electrical length} = 15/(f_1 + f_2)$$

where f_1 = start frequency

f_2 = stop frequency

$(f_1 + f_2)/2$ = center frequency

At very high microwave frequencies (>20 GHz) $1/4$ wavelength lines become short and may be difficult to build. A solution for this problem would then be to simply construct a THRU and LINE which differ by $1/4$ wavelength. This does, however, require a non-zero length THRU.

Example: Selecting Optimal THRU and LINE Lengths

Assuming a transmission media that exhibits linear phase, the following expression can be used to select a LINE with $1/4$ wavelength line at the center frequency.

$$\begin{aligned}\text{Electrical Length (cm)} &= \frac{(\text{LINE} - \text{THRU})}{[f_1 (\text{GHz}) + f_2 (\text{GHz})]} \quad [1] \\ &= \frac{15}{[0.75 (\text{GHz}) + 26.5 (\text{GHz})]} \\ &= 0.55 \text{ cm}\end{aligned}$$

$$\begin{aligned}f_1 &= 0.75 \text{ GHz} \\ f_2 &= 26.5 \text{ GHz}\end{aligned}$$

Electrical length can be related to physical length when the effective permittivity of the dielectric is known.

To determine whether this LINE meets the conditions of acceptable insertion phase, the following expression can be used:

$$\begin{aligned}\text{Phase (degrees)} &= (360 \times f \times l) / c \quad [2] \\ &= 12 \times f (\text{GHz}) \times l (\text{cm})\end{aligned}$$

$$\text{At } 0.75 \text{ GHz} = 5 \text{ degrees}$$

$$\text{At } 26.5 \text{ GHz} = 175 \text{ degrees}$$

The 0.55 cm LINE does not meet the recommended insertion phase requirements (20 and 160 degrees). In order to cover greater than an 8:1 frequency span, multiple lines must be used. If the frequency span is less than 64:1, then two THRU/LINE pairs will be sufficient.

The desired frequency span must be divided, allowing one $1/4$ wavelength LINE to be used over the lower portion of the frequency span and a second to be used for the upper band. The optimal break frequency is the geometric mean frequency $[\sqrt{f_1 \times f_2}]$. The geometric mean of 0.75 GHz and 26.5 GHz is about 4.5 GHz. Using equation [1] the LINE for the 0.75 to 4.5 GHz band would be equal to 2.86 cm, and the line for the 4.5 to 26.5 GHz band, 0.48 cm.

Defining TRL Standards

Once appropriate standards have been selected, they must be defined mathematically and entered into the calibration kit registers of the HP 8510B. Under the CAL menu, there are submenus, MODIFY CAL 1 and MODIFY CAL 2. Either register may be modified to accept user-specified definitions. Default values for the TRL standards may exist, but can be changed simply by entering a new value. Further information on defining calibration standards in the HP 8510 can be found in Hewlett-Packard Product Note 8510-5 "Specifying calibration standards for use with the HP 8510 network analyzer."

Although a variety of options and measurement conditions exist, there are three fundamental classes into which the TRL calibration technique will be applied.

1. TRL with a zero-length THRU
2. TRL with a non-zero-length THRU (sometimes referred to as LRL), reference plane set by THRU
3. TRL with a non-zero-length THRU, reference plane set by REFLECT

Implementation of TRL is the simplest in situations when realizing a zero-length THRU is possible. Cases exist, however, which require the use of a non-zero-length THRU. An example would be calibrating coaxial test ports that are of the same sex – a direct THRU connection is impossible.

CASE 1 Typical applications: Coaxial 7 mm, Waveguide, microstrip

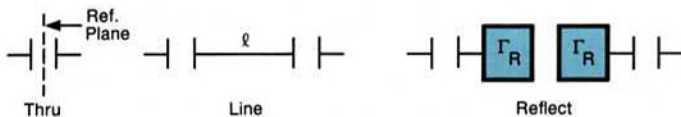

Zero-length THRU (sets reference plane), Multiple LINES, REFLECT is a nominal short circuit.

In this case the frequency span and LINES selected in the previous example will be used. The default standard numbers in the HP 8510B for the THRU, REFLECT and LINE classes are 14, 18 and 15, respectively. The THRU and REFLECT assignments will not be modified. The LINE class requires a second standard. This example will use standard numbers 15 and 16 to accommodate the 0.45 and 2.86 cm LINES. These assignments are shown in Table 2.

Table 2. CAL KIT definitions for Case 1.

STANDARD DEFINITIONS

STANDARD ¹		C0 x10 ⁻¹⁵ F	C1 x10 ⁻¹⁷ F/Hz	C2 x10 ⁻²⁰ F/Hz ²	C3 x10 ⁻²² F/Hz ³	FIXED OR? SLIDING	TERMINAL IMPEDANCE Ω ²	OFFSET			FREQUENCY (GHz) ⁴		COAX or WAVEGUIDE	STND LABEL
NO.	TYPE	L0 x10 ⁻¹² H	L1 x10 ⁻²⁴ H/Hz	L2 x10 ⁻³² H/Hz ²	L3 x10 ⁻⁴² H/Hz ³			DELAY ps	Z ₀ Ω	LOSS G(2)/s	MIN	MAX		
14	Delay							0			.75	26.5	C	Thru
15	Delay							95	50		.75	4.5	C	Line1
16	Delay							16	50		4.49	26.5	C	Line2
17														
18	Short	0	0	0	0			0			.75	26.5	C	Short

CALIBRATION KIT Case 1

TAPE FILE NUMBER _____

STANDARD CLASS ASSIGNMENTS	A	B	C	D	E	F	G	STANDARD CLASS LABEL
TRL Thru	14							Thru
TRL Reflect	18							Open
TRL Line	15	16						Lines

Each of the standards must be defined in terms of the coefficients required by the Standard Definitions Table.

THRU (standard number 14) is specified to have an Offset Delay of 0 picoseconds and operate over the 0.75 to 26.5 GHz frequency range. A zero-length THRU can be used over any frequency span that the transmission medium can support. Since the Offset Delay of a zero-length THRU is accurately known, it is typically used to set the reference plane.

REFLECT (standard number 18) is a nominal flush (zero-length) short circuit. Only nominal specification of its phase is required. It is specified to have an offset delay of 0 picoseconds, and operate over the 0.75 to 26.5 GHz frequency range. Although the finite inductance of the short circuit can be modeled using L_0 , L_1 , L_2 and L_3 , only approximate phase information is required. If the short circuit were offset from the reference plane by more than 90 degrees at the maximum frequency (see equation [2]), an approximation of its Offset Delay should be entered.

LINE (standard number 15) is the 2.86 cm LINE. The approximate Offset Delay should be computed.

$$\begin{aligned}\text{Offset Delay (s)} &= \text{Electrical Length (cm)} / c \text{ (cm/s)} \\ &= 2.86 \text{ cm} / 2.9979 \times 10^{10} \text{ cm/s} \\ &= 95 \text{ picoseconds}\end{aligned}$$

The Offset Loss does not have to be specified. The Offset Z_0 is specified as the known characteristic impedance of the LINE. In this case, the LINES are both assumed to be equal to 50 ohms. The Minimum Frequency on this LINE is 0.75 GHz, although it could be used to a lower frequency. The Maximum Frequency is specified as 4.5 GHz.

LINE (standard number 16) is the 0.48 cm LINE. The approximate Offset Delay is 16 picoseconds. Again the Offset Loss does not have to be specified and the Offset Z_0 set to 50 ohms. The Minimum Frequency is specified as 4.499 GHz, to provide some overlap at the boundary frequency, 4.5 GHz. The Maximum Frequency is set to 26.5 GHz.

The class assignments and standard definitions have been completed, these values can be entered into the HP 8510B MODIFY CAL 1 or MODIFY CAL 2 registers. To enter these values, under the CAL menu, select MORE and MODIFY CAL 1 or 2. The submenu shown in Figure 17a will appear.

Modify Cal Kit Menu



TRL Options Menu



MODIFY CAL KIT MENU

DEFINE STANDARDS: First specify the number of the standard to be defined, then enter the coefficients for each.

SPECIFY CLASS: The corresponding standard numbers for the THRU, REFLECT and LINE classes can be specified.

LABEL CLASS: Appropriate user-defined labels can be entered.

TRL OPTIONS: The submenu shown in Figure 17b will appear. CAL Z₀: LINE Z₀ sets the Z₀ relative to the impedance of the LINE standards. CAL Z₀: SYSTEM Z₀ is used to correct for absolute impedance versus frequency in coaxial transmission line (Requires knowledge of how the Z₀ varies). SET REF allows either the THRU or the REFLECT to set the location of the reference plane. LOWBAND FREQ is the maximum frequency at which the open-short-load calibration will be used. This is used in coaxial calibration when transmission lines become too long to be practical.

LABEL KIT: Appropriate user defined label for modified kit can be entered.

KIT DONE: Select when modification process is complete. This saves the definitions into the HP 8510B's non-volatile storage.

Figure 17. (a) MODIFY CAL KIT and (b) TRL OPTIONS menus

CASE 2
Typical applications: On-wafer, PC board example, sexed connectors (3.5 mm and Type N coaxial)

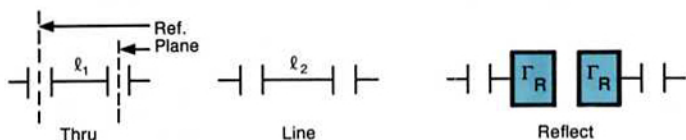

Non-zero-length THRU (sets reference plane), Multiple LINES, REFLECT is a nominal open circuit

The definitions in Case 1 will be used with the following differences – Non-zero-length THRU (2.0 cm), Nominal LINE lengths apply to the difference between the THRU and each LINE; a nominal open rather than a short circuit is used. The Class Assignments remain the same as in Case 1. The new standard definitions are shown in Table 3.

Table 3. CAL KIT definitions for Case 2.

STANDARD DEFINITIONS										CALIBRATION KIT Case 2									
										TAPE FILE NUMBER									
STANDARD ¹	NO.	TYPE	C0		C1		C2		C3		FIXED OR ² SLIDING	TERMINAL IMPEDANCE Ω ³	OFFSET			FREQUENCY (GHz) ⁴		COAX or WAVEGUIDE	STND LABEL
			x10 ⁻¹³ F	x10 ⁻¹⁴ H	x10 ⁻²⁷ F/Hz	x10 ⁻²⁴ H/Hz	x10 ⁻²⁴ F/Hz ²	x10 ⁻³² H/Hz ²	x10 ⁻⁴⁵ F/Hz ³	x10 ⁻⁴² H/Hz ³			DELAY ps	Z ₀ Ω	LOSS G/2/s	MIN	MAX		
	14	Delay										66.7	50		.75	26.5	C	Line 1	
	15	Delay										162	50		.75	4.5	C	Line 2	
	16	Delay										82.7	50		4.49	26.5	C	Line 3	
	17																		
	18	Open	0		0		0		0			0			.75	26.5	C	Open	

STANDARD CLASS ASSIGNMENTS	A	B	C	D	E	F	G	STANDARD CLASS LABEL
TRL Thru	14							Thru
TRL Reflect	18							Open
TRL Line	15	16						Lines

THRU (standard number 14) has an electrical length of 2.0 cm, which corresponds to an Offset Delay of 66.7 picoseconds. Since this THRU will be used to set the reference plane, its delay must be accurately specified. The Z_0 of this THRU must be the same as that of the LINES. It will be assumed that the THRU and both LINES have an Offset Z_0 of 50 ohms. The THRU will have some finite attenuation, but it does not need to be specified. The frequency range of this THRU is the same as in Case 1.

REFLECT (standard number 18) is a flush open circuit. Again only an approximation of its phase response is required. Unshielded open circuits may exhibit significant radiation and fringing capacitance. The nominal phase shift due to fringing capacitance can be ignored (unless it is greater than 90 degrees). If the open circuit radiates energy, its reflection coefficient will be dependent on nearby objects and may not be same on both ports. This example will assume negligible capacitance. (If this assumption is erroneous, a 180 phase discontinuity will occur at the frequency where the actual phase shift exceeds 90 degrees. This phase and frequency data can be used to compute effective capacitance.⁵ Offset Delay is 0 seconds, Loss and Z_0 are unspecified. The same frequency range will be applied.

LINE (standard number 15) corresponds to a transmission line which is 2.86 cm longer than the THRU. When a non-zero-length THRU is used, the length requirements for each LINE standard applies to the difference in electrical length between the THRU and LINE. To satisfy the LINE length requirements for the 0.75 to 4.5 GHz frequency span this LINE must have an electrical length of 4.86 cm or 162 picoseconds. The other parameters remain the same as in Case 1 for this standard.

LINE (standard number 16) corresponds to a transmission line which is 0.48 cm longer than the THRU, for a total of 2.48 cm. The equivalent Offset Delay is 82.7 picoseconds. The other parameters remain the same as in Case 1 for this standard.

Notice that the difference in Offset Delays for the THRU and each LINE corresponds to the Offset Delays for the respective LINES in Case 1.

When the class assignments and definitions are complete, these values can be entered into the HP 8510B using the same procedures as in Case 1.

CASE 3 Typical Applications: Sexed connectors (3.5 mm and Type N)

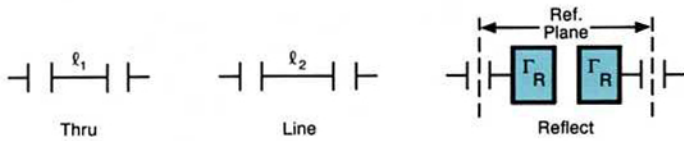

Non-zero-length THRU, Multiple LINES, REFLECT is a precision short circuit (sets reference plane). The definitions in this case will be the same as in Case 2 with the following differences — a precision short circuit will be used as the REFLECT standard and it will be used to set the reference plane. Use of a precision REFLECT standard, can be useful in situations where it is difficult to determine the exact electrical length of a non-zero-length THRU.

The Class Assignments are the as Case 1. The standard definitions for the THRU and both LINES is the same as Case 2.

REFLECT (standard number 18) will be used to set the reference plane, therefore, precise knowledge of its phase response is required. For simplicity, a flush short circuit will be used, although an offset short circuit (of known Offset Delay) could also be used. In many situations, short circuit inductance will exhibit a negligible effect. If significant inductance exists, it can be modeled using the L_0 , L_1 , L_2 , and L_3 coefficients. The Offset Delay is 0 picoseconds, Loss and Z_0 are unspecified. The same frequency span as Cases 1 and 2 will be used.

The class assignments and standard definitions can be entered into the HP 8510B using the same procedures as Cases 1 and 2. Under TRL OPTIONS, SET REF: REFLECT should be selected over the default condition, SET REF THRU.

Performing the Calibration

Calibration Sequence

The following procedure describes a typical calibration process for a fixtured measurement.

1. Configure a 2-port S-parameter measurement system. The fixture will be connected at the coaxial test ports.
2. Press **PRESET** on the HP 8510B. This brings the network analyzer to a known state.
3. Set the desired stimulus conditions for measurement, such as start and stop frequencies, number of points, power level, averaging factor.
4. To begin the calibration process select the **CAL** menu. Any of the seven calibration techniques can be selected by pressing the corresponding display softkey.
5. Press **TRL 2-PORT**. The TRL calibration submenu, shown in Figure 18, will be displayed. The THRU, S11REFLECT, S22REFLECT and ISOLATION and LINE calibrations can be performed in any convenient order. Lowband REFLECTION will not be used in this example⁵
6. Connect the fixture halves together as shown in Figure 10, step 1. Press **THRU**. All four S-parameters and the ratio of the detected incident signals (a_1 and a_2) are displayed and measured. When these measurements are complete, **THRU** is underlined. The scale or format of any of the S-parameters can be changed during calibration. To return to the same point in the calibration, select **RESUME CAL SEQUENCE** under the **CAL** menu.

TRL 2-Port Cal Menu

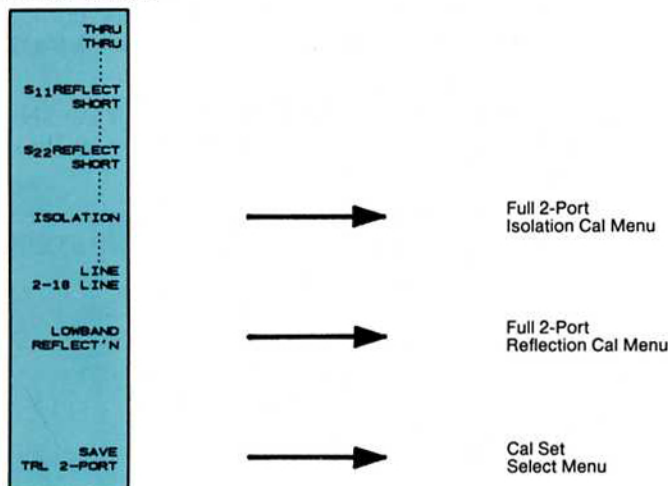

Figure 18. TRL 2-PORT calibration menu.

7. Disconnect the fixture halves. Insert the flush short circuit between the fixture halves as shown in Figure 10, step 2.
8. Press **S11REFLECT**. The reflection coefficient (S_{11}) is measured. When the sweep or sweeps are complete **S11REFLECT** is underlined.
9. Press **S22REFLECT**. S_{22} is measured.
10. To measure the systematic crosstalk, Isolation is measured (S_{21} and S_{12}) with each port terminated. When systematic crosstalk is sufficiently below the levels that are to be measured, as in this instance, it does not have to be characterized. Press **ISOLATION**, **OMIT ISOLATION**, **ISOLATION DONE**.
11. Remove the short circuit from between the fixture halves and insert the LINE.
12. Press **LINE**. All four S-parameters of the 0.5 cm LINE and the ratio of the incident signals will be measured. If the frequency span is beyond the range of a single line, another LINE could be measured at this point.
13. Press **SAVE TRL CAL** and select the desired **CAL SET**. Error-correction is automatically turned on.

Checking the Performance

Once a calibration has been performed, and error correction applied, some confidence in measurement integrity must be derived. In coaxial connector families, verification kits exist. These kits contain devices whose characteristics are precisely and independently known. When these devices are measured, the difference between the displayed results and the known values indicate the level of measurement accuracy. In non-coaxial cases, unfortunately, these verification devices do not exist. As a result, it will be difficult to state the absolute accuracy of such measurements.

However, there are some performance checks that can be made to provide some insight into the measurement integrity.

Connection repeatability is the largest single factor that will limit the effectiveness of the calibration. Connection repeatability can be evaluated simply. Take a single S-parameter measurement and store its response into memory. Break the connection, reconnect the same device, and then re-measure. The DATA-MEMORY trace math feature allows repeatability to be displayed automatically. When measuring a LINE standard the repeatability of S_{11} presents a fundamental limit for the effective directivity that may be achieved with error correction applied. Measurement repeatability for the example fixture is shown in Figure 19. Repeatability, up to 8 GHz, is shown to be better than 40 dB.

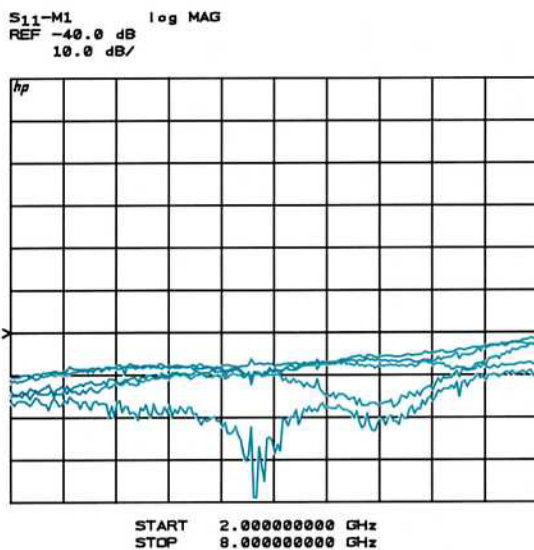

Figure 19. Connection repeatability of the microstrip test fixture.

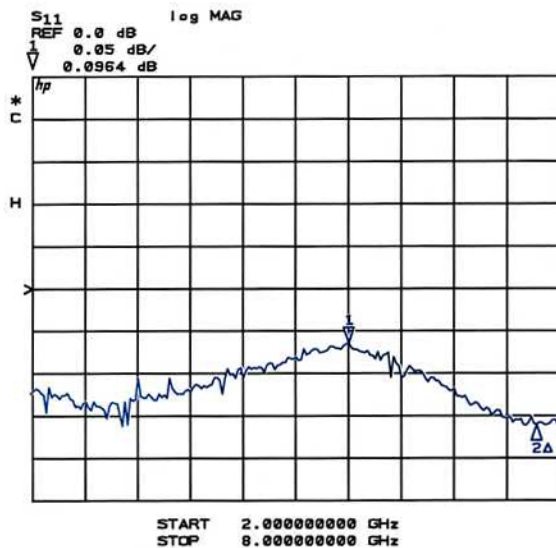

Figure 20. Example measurement of a microstrip offset short circuit showing periodic variation due to residual source match error.

Second to repeatability, the systematic microwave errors are another major source of measurement uncertainty. Some of the effective systematic errors can be measured if an ideal transmission line is available. This transmission line must not be one of the LINES that was used during calibration. Since an ideal transmission line by definition has infinite return loss, any return loss that is measured may be considered an error (to the extent that this Line is considered perfect). To show how well the systematic microwave errors have been removed, the return loss of a 1 cm transmission line is shown in Figure 2. The measured return loss is better than 30 dB.

Measurement of an offset short circuit termination can be used to evaluate effective port match error. For this measurement, a short circuit is connected at the end of the 1 cm transmission line. Ideally this device would have a smooth monotonic response. In the frequency domain, mismatch error causes a periodic ripple on the measured data. The measurement shown in Figure 20 shows a variation of less than 0.098 dB.

Summary

The HP 8510B can be used to make error-corrected measurements in a variety of transmission media. Proper application of the HP 8510 TRL calibration method allows for accurate characterization on coaxial and non-coaxial devices using simple, realizable standards. Examples were shown illustrating how this method can be used to characterize and remove the effects of a microstrip test fixture and a coax-to-PC board launch. Application of TRL can be easily extended to waveguide and planar transmission media like stripline. This new technique augments the other methods established by previous HP vector network analyzers and does not require an external controller or any additional software. All of the existing speed, performance and features of the HP 8510B are maintained when this technique is applied. Further this technique can be added to any existing HP 8510A network analyzer through the HP 85103 Performance Upgrade Package.

Bibliography

1. Franzen, N.R., Speciale R.A., "A new procedure for system calibration and error removal in automated S-parameter measurements," Proc. 5th European Microwave Conference, Sept 1975.
2. Engen, G.F., Hoer C.A., "Thru-Reflect-Line: An improved technique for calibrating the dual six-port automatic network analyzer," IEEE Trans. Microwave Theory and Techniques, December 1979.
3. Sobol, H., "Applications of integrated circuit technology to microwave frequencies," August 1971.
4. Gonzalez, G., "Microwave transistor amplifiers, analysis and design," Prentice-Hall, 1984.
5. Hewlett-Packard Product Note 8510-5, "Specifying calibration standards for use with the HP 8510 network analyzer," March 1986.

For information about Hewlett-Packard products and services, telephone the local Hewlett-Packard sales and support office listed in your telephone directory. Or write to the appropriate address listed below.

U.S.A.

Hewlett-Packard
4 Choke Cherry Road
Rockville, MD 20850

Hewlett-Packard
5201 Tollview Drive
Rolling Meadows, IL 60008

Hewlett-Packard
2000 South Park Place
Atlanta, GA 30339

Hewlett-Packard
5161 Lankershim Blvd.
North Hollywood, CA 91601

Canada

Hewlett-Packard (Canada) Ltd.
6877 Goreway Drive
Mississauga, Ontario L4V 1M8
Tel: (416) 678-9430

United Kingdom

Hewlett-Packard Ltd.
King Street Lane
Winnersh, Wokingham
Berkshire RG11 5AR
Tel: 734/78 47 74

France

Hewlett-Packard France
Parc d'activités du Bois Briard
2, avenue du Lac
91040 Evry Cedex
Tel: 1 60 77 83 83

German Federal Republic

Hewlett-Packard GmbH
Hewlett-Packard-Strasse
Postfach 1641
D-6380 Bad Homburg
West Germany
Tel: 06172/400-0

Italy

Hewlett-Packard Italiana S.p.A.
Via G. Di Vittorio 9
I-20063 Cernusco Sul
Naviglio (Milano)
Tel: 02/92 36 91

Benelux and Scandinavia

Hewlett-Packard S.A.
Uilenstede 475
P.O. Box 999
NL-1183 AG Amstelveen
The Netherlands
Tel: (31) 20/43 77 71

Mediterranean and Middle East

Hewlett-Packard S.A.
Mediterranean and Middle East
Operations
Atrina Centre
32 Kifissias Avenue
Paradissos-Amarousion, Athens
Greece
Tel: (30) 682 88 11

South and East Europe, Africa

Hewlett-Packard S.A.
7, rue du Bois-du-Lan
CH-1217 Meyrin 2, Geneva
Switzerland
Tel: (41) 22/83 12 12

Japan

Yokogawa-Hewlett-Packard Ltd.
29-21 Takaido-Higashi, 3 Chome
Suginami-ku, Tokyo 168
Tel: 03 (331) 6111

Asia

Hewlett-Packard Asia Ltd.
47/F, 26 Harbour Road,
Wanchai, Hong Kong
G.P.O. Box 863, Hong Kong
Tel: (852) 5-8330833

Australasia

Hewlett-Packard Australia Ltd.
31-41 Joseph Street
Blackburn, Victoria 3130
Australia
Tel: (61) 895-2895

Other International Areas

Hewlett-Packard
Intercontinental Headquarters
3495 Deer Creek Road
Palo Alto, CA 94304

Corporate Headquarters
Hewlett-Packard
3000 Hanover Street
Palo Alto, CA 94304