

# 16034G-01A

## S E R V I C E N O T E

---

Supersedes:  
16034G-01

### 16034G SMD Test Fixture

**Serial Numbers:**

**Non-RoHS Fixture “MY44100001 – MY44199999”**

**OR**

**RoHS Fixture “MY44200001 – MY44299999”**

**This service note provides the updated part numbers and figures for both RoHS and non-RoHS 16034G SMD Test Fixture**

**Parts Required:**

Parts required depends on whether RoHS or non-RoHS 16034G is serviced.

**Non-RoHS unit** – Refer to [Situation 1](#)

**RoHS unit** – Refer to [Situation 2](#)

### ADMINISTRATIVE INFORMATION

SERVICE NOTE CLASSIFICATION:	
<b>INFORMATION ONLY</b>	
<input type="checkbox"/> Calibration Required	PRODUCT LINE: WN
<input checked="" type="checkbox"/> Calibration NOT Required	AUTHOR: LS
ADDITIONAL INFORMATION: Support part information for non-RoHS and RoHS16034G SMD Test Fixture.	

© AGILENT TECHNOLOGIES, INC. 2013  
PRINTED IN U.S.A.

July 12, 2013

Rev. 21



**Situation 1:**  
**For non-RoHS 16034G SMD Test Fixture**  
**(S/N: MY441xxxxx and below).**

**Solution/Action:**

Shown are the supported parts and their respective RoHS compliant replacement support part. RoHS conversion involves with design and dimension change which result in the RoHS support part backward incompatible with non-RoHS 16034G. Special handling is needed while using the RoHS replacement part on non-RoHS 16034G. The original support part number is replaced by the respective "RoHS Compliant Replacement Part". Once the original support part is depleted, please proceed to obtain the RoHS compliant support part. Please refer to figure and table 1-1, 1-2 for the respective replacement part accordingly.

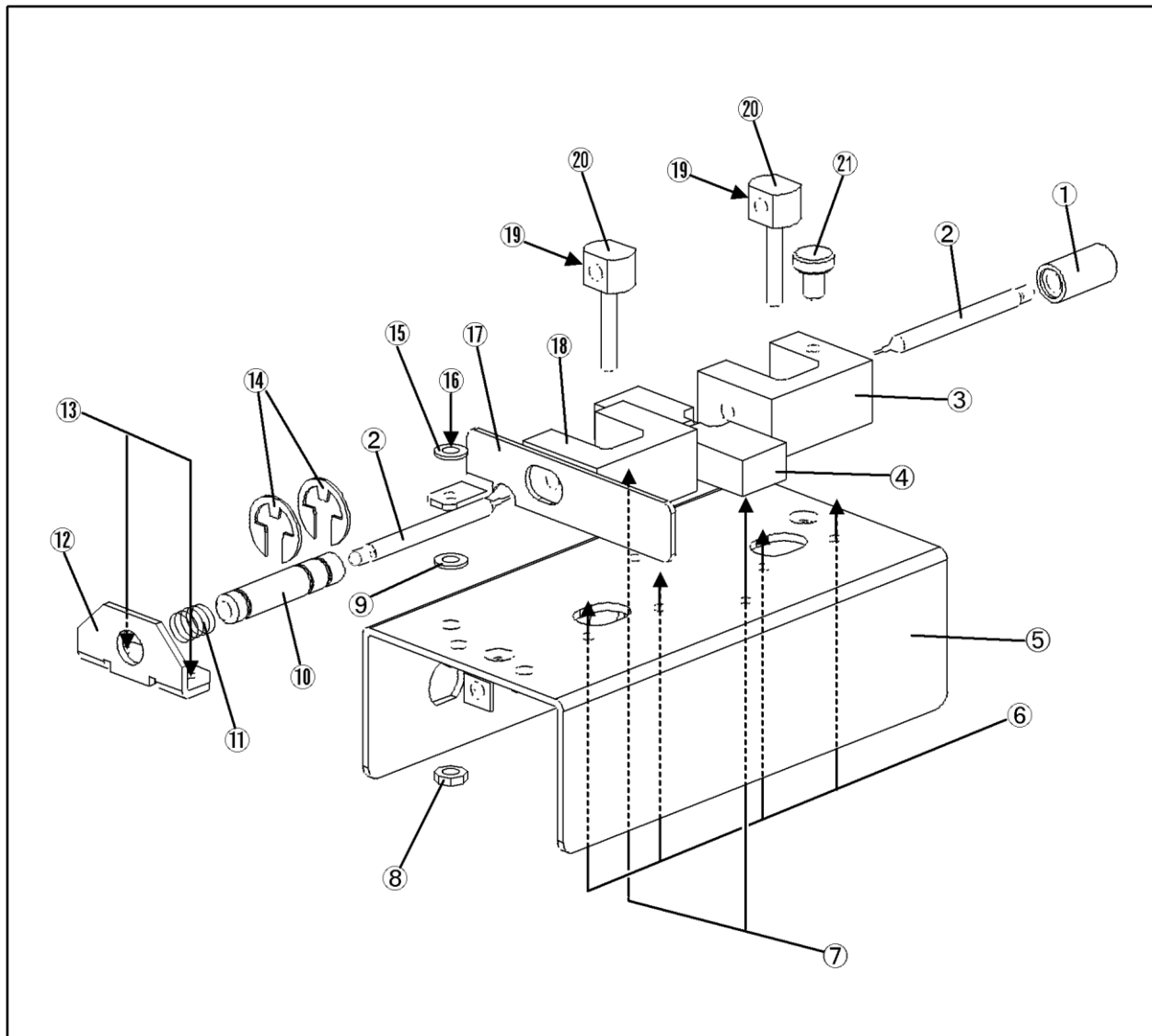

**Figure 1-1**

**NOTE: For RoHS Compliant Upper Level Assembly Replacement Part, if multiple parts are replaced by a common higher assembly part, only order ONE part of the higher level common assembly.**

Shown in table 1-1, 1-2 are the original support part and its compatible RoHS replacement part/assembly.

Remarks:

<\*1> Replace all the associated parts marked with <\*1> as they are mutually dependent.

**Table 1-1:**

Ref/D	Part Number	Description	Qty.	RoHS Compliant Replacement Part	Description	Qty.
1	16034-25013	KNOB	1	16034-25013	KNOB	1
2	16034-24011 (16034-24051)	ELECTRODE(16034G)	2	16034-24651	ELECTRODE (16034G)	2
3	16034-25011	BLOCK	1	<*1>Set change: 16034-25614 (16034G)	BLOCK (16034G)	1
4	16034-25014	BLOCK (16034G)	1	<*1>Set change: 16034-25614 (16034G)	BLOCK (16034G)	1
5	16034-04011	COVER TOP(16034G)	1	16034-04611	COVER TOP(16034G)	1
6	0515-1550	SCREW	4	0515-0372	SCREW	4
7	0515-1550	SCREW	2	0515-0372	SCREW	2
8	0535-0031	NUT-HEX W/LOCKER	1	0535-0031	NUT-HEX W/LOCKER	1
9	3050-1139	WASHER	1	3050-1139	WASHER	1
10	16034-25015	KNOB	1	16034-25015	KNOB	1
11	16034-08001	SPRING	1	16034-08001	SPRING	1
12	16034-01211	BRACKET	1	16034-01211	BRACKET	1
13	0515-1550	SCREW	2	0515-0372	SCREW	2
14	0510-0083	RETAINER	2	0510-0083	RETAINER	2
15	3050-0891	WASHER	1	3050-0891	WASHER	1
16	0515-0920	SCREW	1	0515-1141	SCREW	1
17	16034-05011	LEVER	1	16034-05011	LEVER	1
18	16034-25012	BLOCK	1	<*1>Set change: 16034-25614 (16034G)	BLOCK (16034G)	1
19	3030-0007	SCREW	2	3030-0007	SCREW	2
20	16034-24012	PLUG	2	16034-24012	PLUG	2
21	16034-24014	SCREW	1	16034-24014	SCREW	1

Remarks:

<\*1> Replace all the associated parts marked with <\*1> as they are mutually dependent.

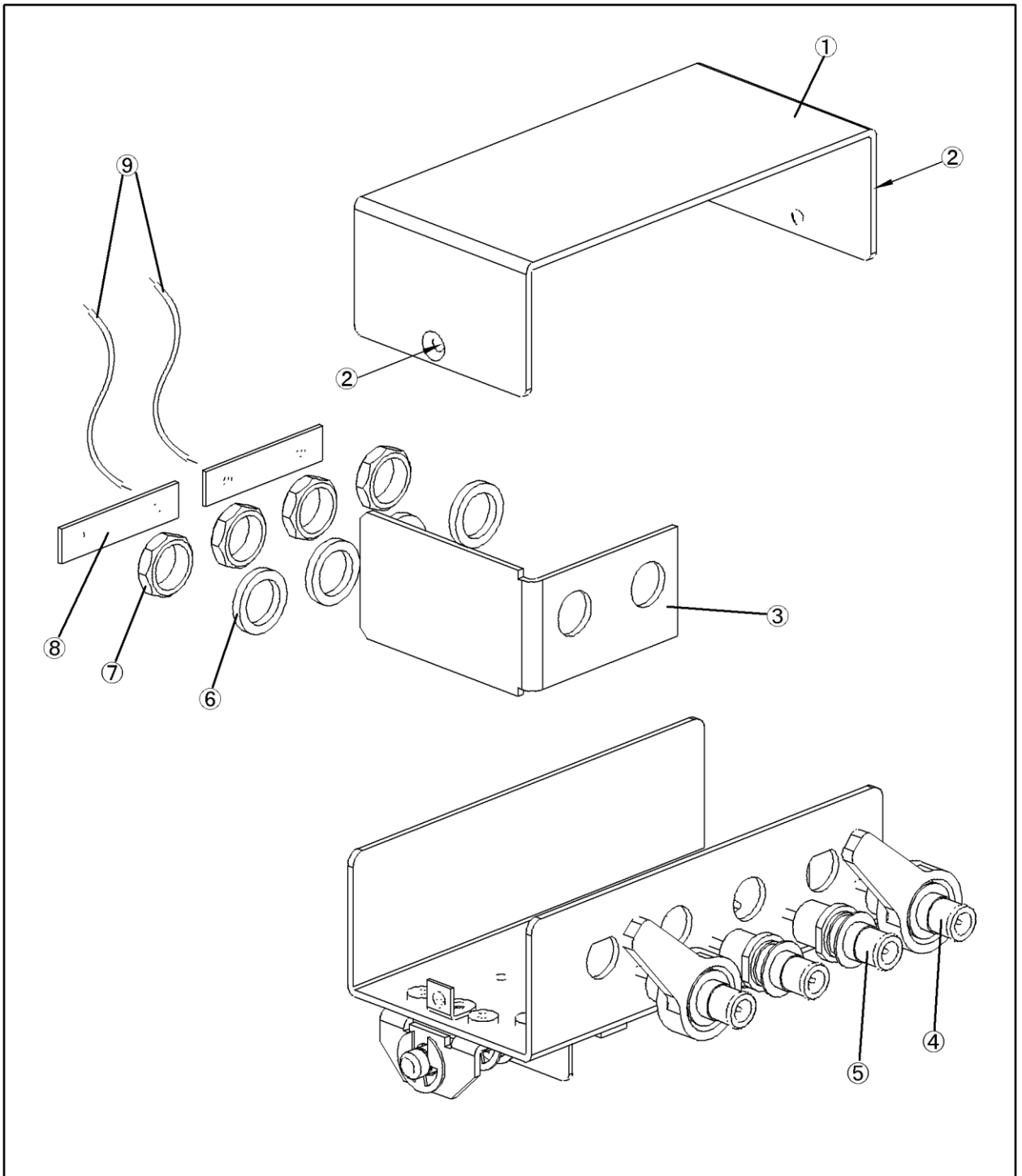

Figure 1-2

**Table 1-2:**

<b>Ref/D</b>	<b>Part Number</b>	<b>Description</b>	<b>Qty.</b>	<b>RoHS Compliant Replacement Part</b>	<b>Description</b>	<b>Qty.</b>
1	16034-04012	COVER BOTTOM	1	16034-04612 (Texture change)	COVER BOTTOM	1
2	0515-0914	SCREW	2	0515-1946	SCREW	2
3	16034-00601 (16034-01212)	PLATE - SHIELD	1	16034-01212	PLATE - SHIELD	1
4	16012-7122	BNC - ASSY	2	5012-8617 (Level color change)	BNC - ASSY	2
5	1250-1798 (16047-60016)	CONNECTOR-BNC	2	5012-8628	CONNECTOR- BNC	2
6	2190-0016	WASHER	4	2190-0016	WASHER	4
7	2950-0043	NUT-HEX-DBL-CHAM	4	2950-0043	NUT-HEX- DBL-CHAM	4
8	16047-00617	PLATE	2	16034-00617 (Do not mix non- RoHS part with RoHS part. Replace both plates with RoHS part if one of the non-RoHS plate is defective)	PLATE	2
9	16034-68021	JUMPER WIRE (2 ea.)	1	16034-68021	JUMPER WIRE (2 ea.)	1

**Situation 2:**  
**For RoHS 16034G SMD Test Fixture**  
**(S/N: MY442xxxxx and above).**

**Solution/Action:**

Shown are the support parts for RoHS compliance 16034G SMD Test Fixture. All the listed items are changed at RoHS conversion. Due to limited availability of RoHS compliance station and technical difficulties in RoHS soldering, only parts and support level that do not require RoHS soldering are supported. Shown are the supported RoHS compliance parts for RoHS 16034G SMD Test Fixture.

Shown in table 2-1, 2-2 and figure 2-1, 2-2 are the respective support parts for RoHS compliance 16034G unit.

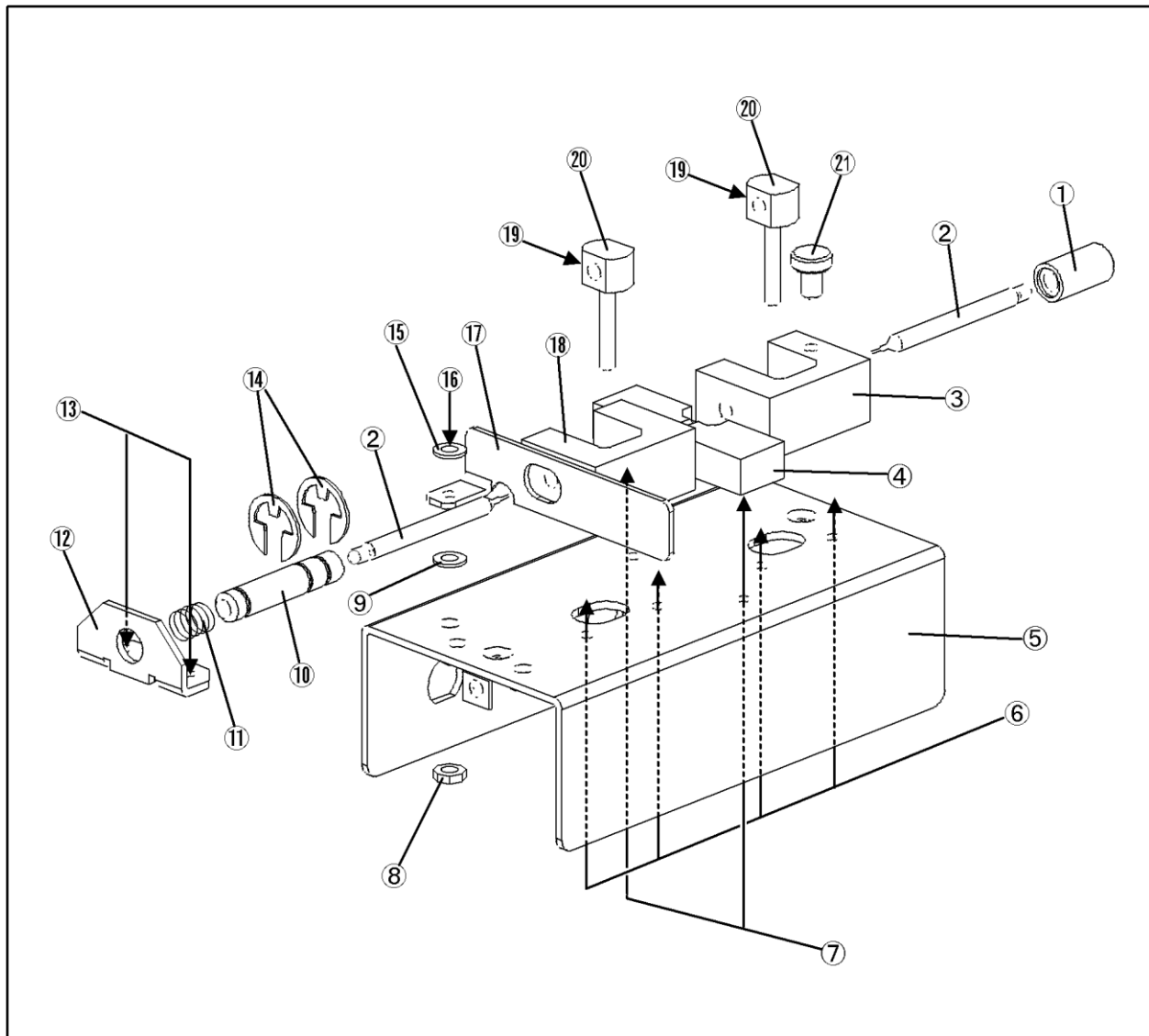

**Figure 2-1**

Table 2-1

<b>Ref/D</b>	<b>Description</b>	<b>RoHS Compliant Replacement Part</b>	<b>Qty.</b>
1	KNOB	16034-25013	1
2	ELECTRODE (16034G)	16034-24651	2
8	NUT-HEX W/LOCKER	0535-0031	1
9	WASHER	3050-1139	1
10	KNOB	16034-25015	1
11	SPRING	16034-08001	1
12	BRACKET	16034-01211	1
14	RETAINER	0510-0083	2
15	WASHER	3050-0891	1
16	SCREW	0515-1141	1
17	LEVER	16034-05011	1
19	SCREW	3030-0007	2

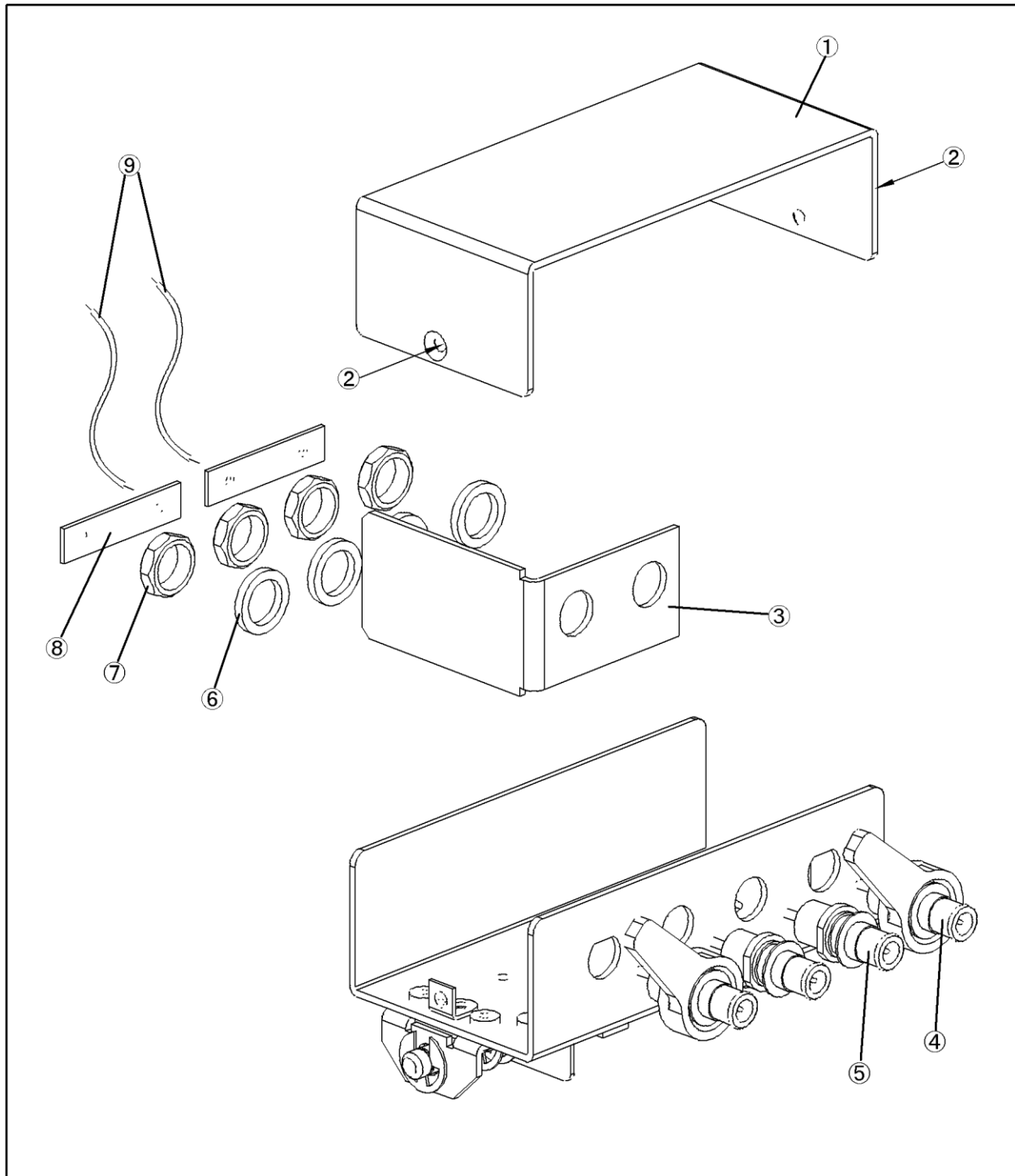

Figure 2-2

Table 2-2

Ref/D	Description	RoHS Compliant Replacement Part	Qty.
1	COVER BOTTOM	16034-04612	1
2	SCREW	0515-1946	2



**Revision History:**

<b>Revision Number</b>	<b>Date</b>	<b>Author</b>	<b>Reason For Change</b>
16034G-01	15 Feb 2013	LS	As published
16034G-01A	12 July 2013	LS	Removed 16034H parts from part lists.