

16047C-01

S E R V I C E N O T E

SUPERSEDES: None

HP 16047C Test Fixture

Duplicate Service Notes: None

Replacing BNC connector and electrode

To Be Performed By: HP-Qualified Personnel

Situation:

When replacing the BNC connectors or the electrodes of the HP 16047C test fixture, the new BNC connectors or electrodes must be carefully assembled along with instructions given below. Otherwise the contact resistance occurs in case physical force is applied on the fixture, and as a result, small impedance measurement becomes unstable. Key points are: (1) The BNC connectors must be mounted to the chassis firmly. (2) The two electrodes must be soldered so that they are parallel to the edge of the chassis.

Solution/Action:

(1) When mounting the BNC connectors

The four BNC connectors must be mounted firmly to the chassis. Especially, for the two center BNC connectors (HP and Ip terminals), hold the BNC connectors with a wrench outside and tighten the nut firmly inside as shown in Figure 1. It is recommended to use the 7/16 inch wrench for holding the BNC connectors outside.

Continued

DATE: 06 June 1994

ADMINISTRATIVE INFORMATION

SERVICE NOTE CLASSIFICATION:

INFORMATION ONLY

AUTHOR:

ENTITY:

ADDITIONAL INFORMATION:

YM

3355

© 1994 HEWLETT-PACKARD COMPANY
PRINTED IN U.S.A.



(2) When soldering the electrodes

When soldering the electrodes to the BNC connectors, insert appropriate four plates between the electrodes and the chassis so that the both two electrodes are exactly parallel to the edge of the chassis as shown in Figure 2. Use the plate whose thickness is 1mm so that the distance between the electrode and the edge of the chassis is uniformly 1mm. Be careful not to put the solder too much on the electrode, because it causes a gap between the electrodes, and the device cannot be held tightly. For more detail about part information, refer to HP 16047C Operating Note (HP P/N 16047-90020).

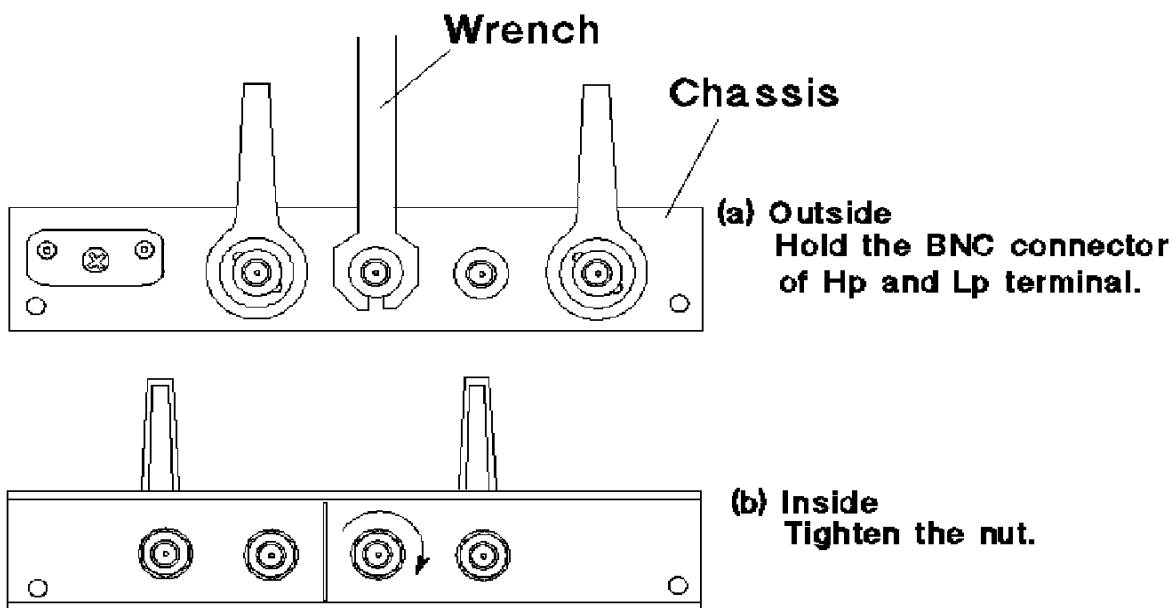

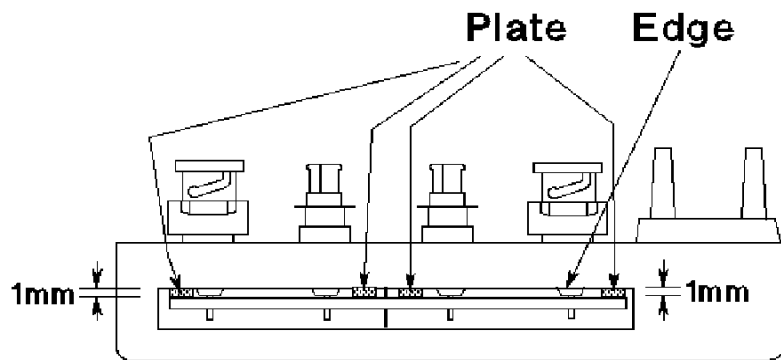

(a) Top View

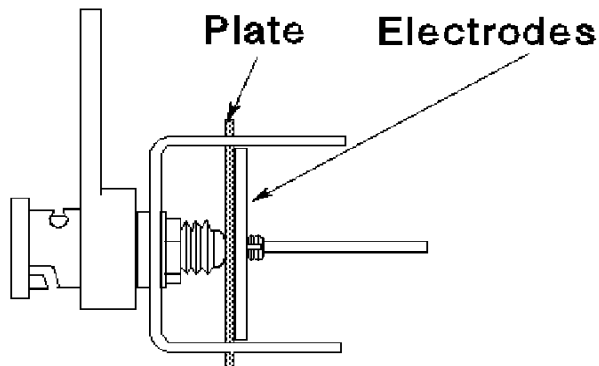

(b) Side View