

E5062A-06

S E R V I C E N O T E

Supersedes:
None

E5062A ENA Series Network Analyzer, 300 kHz to 3 GHz

Serial Numbers: JP1KL00000 to JP1KL99999, MY44100000 to MY44999999 and SG44100000 to SG44999999

When replacing A51 LCD, fasten the TORX T15 screws using a torque screwdriver (set to 1.02 N-m / 9.0 lb-in).

To Be Performed By: Agilent-Qualified Personnel or Customer

Parts Required: NONE

ADMINISTRATIVE INFORMATION

SERVICE NOTE CLASSIFICATION:

INFORMATION ONLY

AUTHOR: jm PRODUCT LINE: WN

ADDITIONAL INFORMATION:

© AGILENT TECHNOLOGIES, INC. 2007
PRINTED IN U.S.A.



May 30, 2007

Situation:

When replacing the A51 LCD, no torque info is shown in the service guide.

If you fasten the screw with over the appropriate torque, A51 LCD might be damaged, and if you fasten the screw with under the appropriate torque, LCD module might not be fixed against the vibration.

Solution/Action:

Fasten the TORX T15 screws (item 11) using a torque screwdriver (set to 1.02 N-m / 9.0 lb-in).

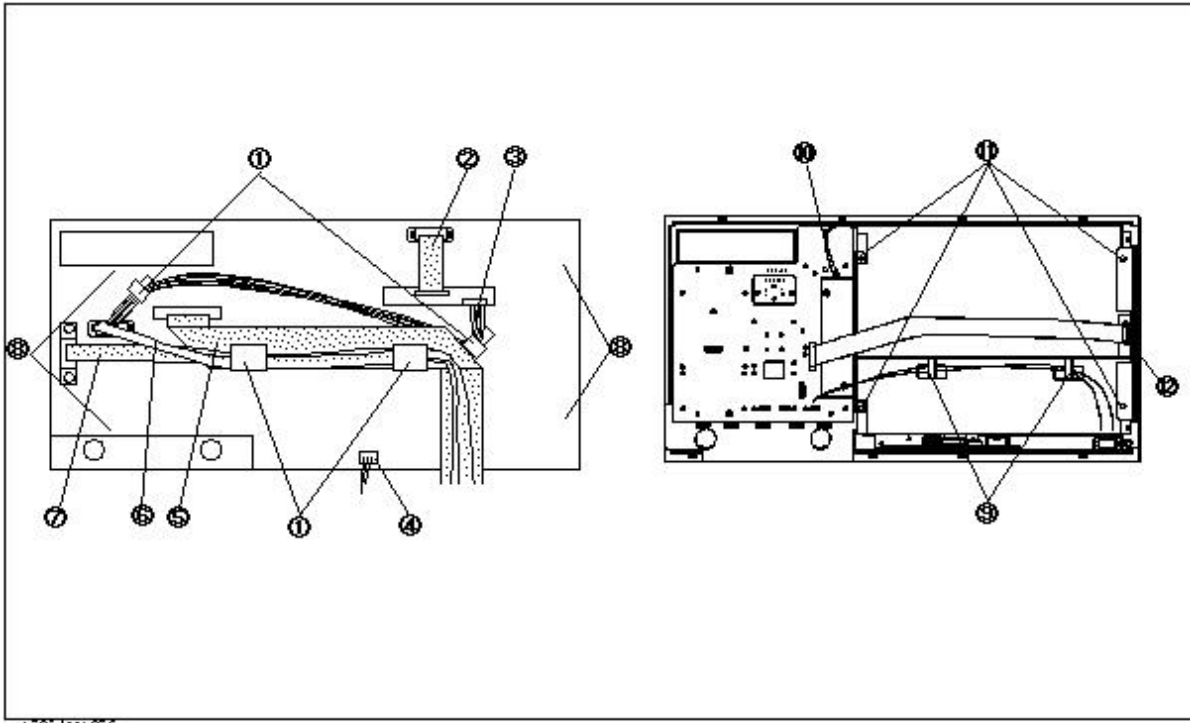

e5062ase01:6

- End of document -