

E5071C-31B

Information Only Service Note

Supersedes:
E5071C-31A

E5071C ENA Series Network Analyzer

Serial Numbers: MY46100001 - MY46199999, SG46100001 - SG46199999;
MY46200001 - MY46299999, SG46200001 - SG46299999;
MY46300001 - MY46399999, SG46300001 - SG46399999

Manufacturing ID Number: N/A

E5071C LCD Touch Panel Display Assembly Replacement Part Change

Parts Required:

[For E5071C Opt 240 to 485 - \(Up to 8.5GHz frequency range\)](#) - E5070-65112 Service-Kit, LCD Touch Panel Assembly, for E5071C is offered (NotForTradeSale)

[For E5071C Opt 2D5 to 4K5 - \(> 8.5GHz and above\)](#) - E5070-65114 Service-Kit, LCD Touch Panel Assembly, for E5071C-20GHz is offered (NotForTradeSale)

ADMINISTRATIVE INFORMATION

Calibration Required
 Calibration NOT Required

PRODUCT LINE: WN
AUTHOR: ls

ADDITIONAL INFORMATION:

This service note communicates the support parts and replacement strategy for E5071C LCD Touch Panel display assembly.

For E5071C Opt 240 to 485 – Up to 8.5 GHz range

Situation:

For E5071C (serial prefix of MY461/SG461, MY462/SG462 and MY463/SG463), due to the part discontinuance by LCD display manufacturer, the E5070-60112 **LCD-Touch Panel Assembly** (with LCD Display with CCFL backlight) is no longer supplied.

The replacing part would be an LCD Touch Panel Display Assembly with LED backlight. In ensuring hardware compatibilities, there would be a list of associated parts required to be replaced whenever the LCD T/P assembly (LCD Display with CCFL backlight) is defective.

Solution/Action (For E5071C Opt 240 to 485 – Up to 8.5 GHz range)

LCD Removal

Refer to E5071C Service Guide (Chapter 6- Replacement Procedure → LCD Replacement) for the step-by-step procedure.

Front Panel Keyboard Removal

Refer to E5071C Service Guide (Chapter 6- Replacement Procedure → Front Panel Keyboard Replacement) for the detailed procedure.

Probe Power and Power Switch Board Removal

Refer to E5071C Service Guide (Chapter 6 → Probe Power and Power Switch Board Replacement (A56) for detailed instructions.

Note: Kindly take note to keep the original parts as some of the assemblies are reusable and replacement is not necessary.

For defective LCD T/P Assembly E5070-60112

In summary, whenever LCD T/P E5070-60112 is identified defective, replace the following parts altogether as they are mutually dependent:

1. LCD T/P assembly (with LED backlight display),
2. Inverter
3. Front Panel (label, panel sub, shield)
4. Cable assemblies,
5. Screws etc.

In this case, apart from replacing the LCD T/P assembly with the replacement part, the inverter is required to be replaced in ensuring the compatibility with the new LCD T/P assembly (with LED backlight). Front panel needs to be replaced as the dimension and the new LCD T/P assembly screw size and location differs on the new LCD T/P display assembly (with LED backlight). Refer to table 1-1 for details.

For other failures (other than LCD T/P assembly E5070-60112)

If the defective part does not include LCD Touch Panel Assembly, proceed to replace the individual defective parts directly as usual. For instances, if the inverter 0950-4420 is found to be defective, replace the inverter alone will be sufficient. Similar applies to Touch Panel controller. Those parts are continuously supported and supplied until further notice. Refer to service guide for detailed instructions.

Table 1-1 Defective LCD T/P Assemblies – Support part strategy.

Table 1-1 depicts the support PN replacement strategy and their dependencies.

Legend:

Direct replacement: Replace one part.

Replace set: Set replacement with dependency. Replace all associated parts with “replace set” remarks.

Common: No part or design change.

New: Newly introduced part on new “LED backlight” design.

Repair kit is offered for ordering convenience in service center.

For Opt 240 to 485 (Up to 8.5GHz) freq. option, order **E5070-65112** Service-Kit, LCD Touch Panel Assembly, for E5071C. (Not for Trade Sale)

Identified Defective Part	Types	Original Installed PN	Description	Qty.	New PN	Description	Qty.	Remarks
Inverter (0950-4420)	Assemblies, Modules	0950-4420	Inverter	1	0950-4420WN	Inverter	1	Direct replacement
Touch Panel Controller (5183-4184)	Assemblies, Modules	5183-4184	Touch Panel Controller	1	5183-4184	Touch Panel Controller	1	Direct Replacement
LCD Touch Panel Assembly (E5070-60112)	Assemblies, Modules	E5070-60112	LCD Touch Panel Assembly	1	E5070-60113	LCD Touch Panel Assembly (With LED backlight)	1	Replace set
		E5071-00222	Panel Sub	1	E5071-00262	Panel Sub	1	Replace set
		E5071-00621	Cover Shield	1	E5071-00633	Cover Shield	1	Replace set
		0950-4420	Inverter	1	0950-5396	Inverter	1	Replace set
		E5071-01211	Inverter Bracket	1	E5071-01241	Inverter Bracket	1	Replace set

		E5071-00252 (Opt 2xx)	Front Panel	1	E5071-00252 (Opt 2xx)	Front Panel	1	Common
		E5070-00273 (Opt 2D5, 2K5)			E5070-00273 (Opt 2D5, 2K5)			
		E5071-00254 (Opt 4xx)			E5071-00254 (Opt 4xx)			
		E5070-00271 (Opt 4D5, 4K5)			E5070-00271 (Opt 4D5, 4K5)			
		[Refer to service guide page 190]	Label (Frequency label)	1	[Refer to service guide page 190]	Label (Frequency label)	1	Common
		5183-4184	Touch Panel Controller	1	5183-4184	Touch Panel Controller	1	Common
		E5071-01238	Touch Panel Controller Bracket	1	E5071-01238	Touch Panel Controller Bracket	1	Common
		E5070-66656	PCA Probe Power	1	E5070-66656	PCA Probe Power	1	Common
		E5070-66655	PCA Front USB	1	E5070-66655	PCA Front USB	1	Common
		E5070-61901	Standby Switch Wire Assembly	1	E5070-61901	Standby Switch Wire Assembly	1	Common
	Cables	E5071-61616	LCD Display - Flat Cable assembly	1	E5070-61699	LCD Display - Flat Cable assembly	1	Replace set

		E5071-61608	Wire assembly, (Inverter to Keyboard)	1	E5061-61654	Wire assembly, LED Driver (Inverter to Keyboard)	1	Replace set
		(None)	(None) Original cable is pre-fitted with LCD T/P assembly	-	E5061-61653	Wire assembly, (Display backlight power)	1	New
		E5071-61611	Wire assembly, (PCA Probe Power to keyboard)	1	E5071-61611	Wire assembly, (PCA Probe Power to keyboard)	1	Common
		E5070-61628	Wire assembly, (Keyboard to T/P controller)	1	E5070-61628	Wire assembly, (Keyboard to T/P controller)	1	Common
	Gasket	0363-0170	RFI-Gasket Strip-Fingers	79	0363-0170	RFI-Gasket Strip-Fingers	79	Common
	Cable Tie	1400-0249	Cable tie	1	1400-0249	Cable tie	3	Common
	Cable Clamp	1400-3377	Cable clamp (On cover shield)	2	1400-1334	Cable clamp (On cover shield)	2	Replace set
		1400-0611	Cable clamp (On cover shield)	1	1400-0611	Cable clamp (On cover shield)	1	Common
		1400-3156	Cable Clamp Nylon	2	1400-3156	Cable Clamp Nylon	2	Common
	Screws	(None)	(None)	-	0515-5711	Screw M4x0.7 - securing LCD Flat cable assembly	2	New

		(None)	(None)	-	0515-0430	Screw M3x0.5 – Underneath the inverter assembly (hidden)	2	New
		(None)	(None)	-	0515-1946	Screw M3x0.5 – Top of the inverter assembly (visible)	2	New
		0515-1402	Screw M3.5x0.6	4	0515-0430	Screw M3x0.5 – Securing the LCD T/P assembly to front panel	4	Replace set
		0515-0430	Screw M3x0.5	2	0515-0375	Screw M3x0.5 – T/P Controller	2	Replace set
		0515-0430	Screw M3x0.5	2	0515-430	Screw M3x0.5 – PCA Probe Power	2	Common
		0515-0430	Screw M3x0.5	8	0515-0430	Screw M3x0.5 – Keyboard	8	Common

For defective LCD T/P Assembly E5070-60112

In summary, whenever LCD T/P E5070-60112 is identified defective, replace the following parts altogether as they are mutually dependent:

LCD Replacement.

1. Install the keyboard on the new front panel sub as shown in figure 1-1.

Note: The front panel, panel sub and cover shield are required to be replaced due to dimension changes. Front panel frequency label should be purchased separately according to unit frequency options.

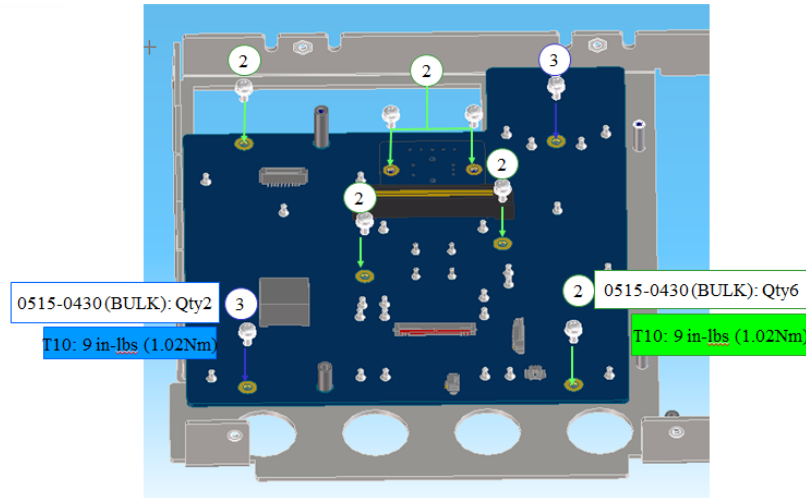

Figure 1-1

2. Install the gaskets as shown in Figure 1-2. Figure 1-3 illustrates the Front panel with the keyboard installed.

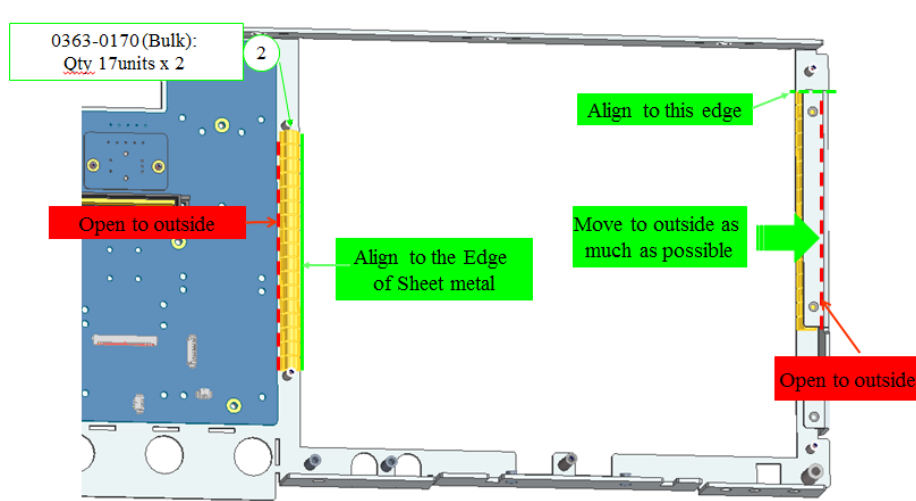

Figure 1-2

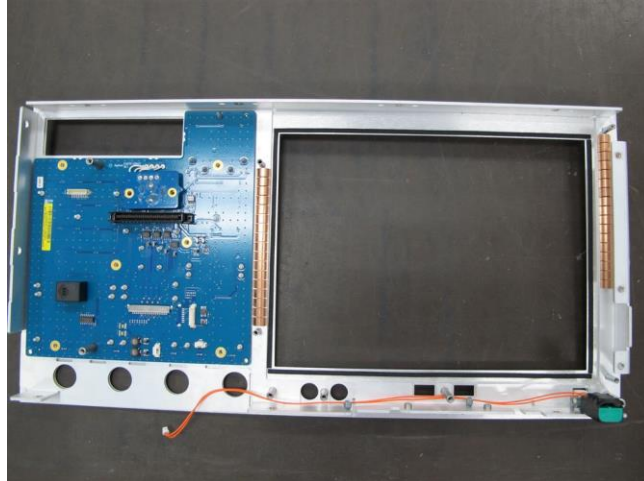

Figure 1-3

3. Install the inverter on the bracket before connect the cable assembly to both ends as shown in figure 1-4

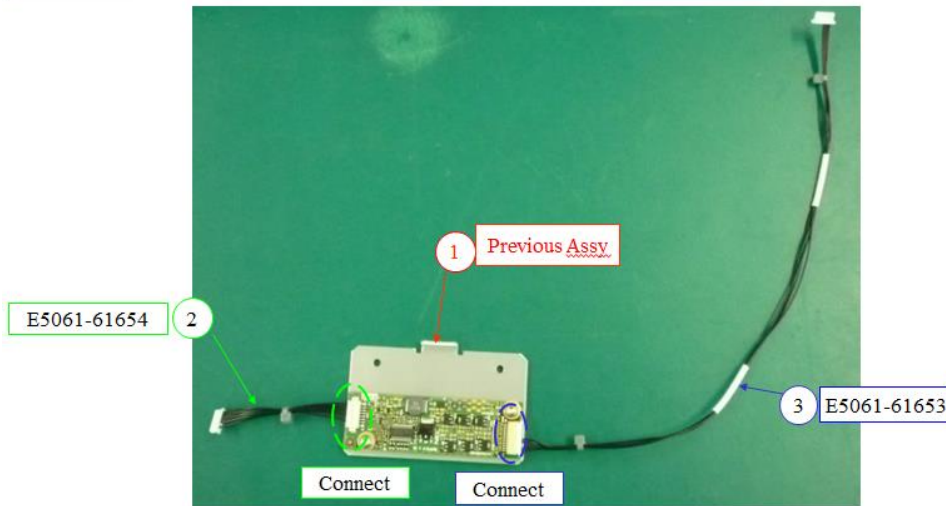

Figure 1-4

4. Install the inverter assembly onto the new CLD T/P display assembly (with LED backlight). Refer to figure 1-5 for details.

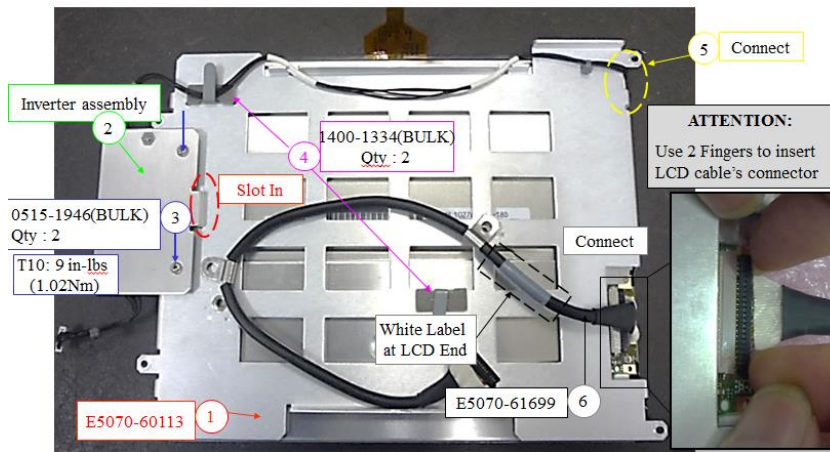

Figure 1-5

5. Route the LCD display assembly cables accordingly.

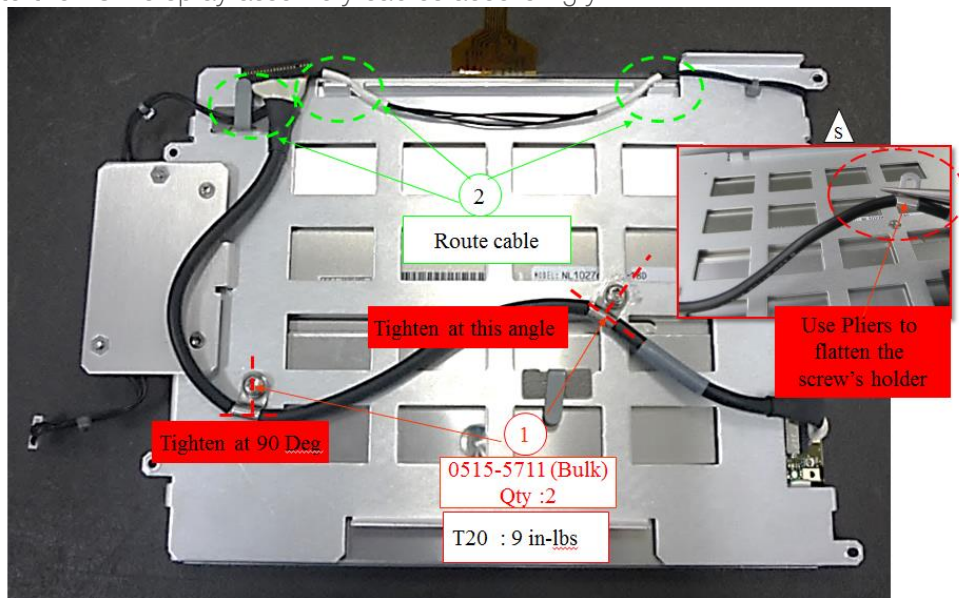

Figure 1-6

6. Install the LCD T/P Display Assembly onto the LCD Front Panel. Fasten the screws according to the following sequence. Connect all cable assemblies as shown in figure 1-7.

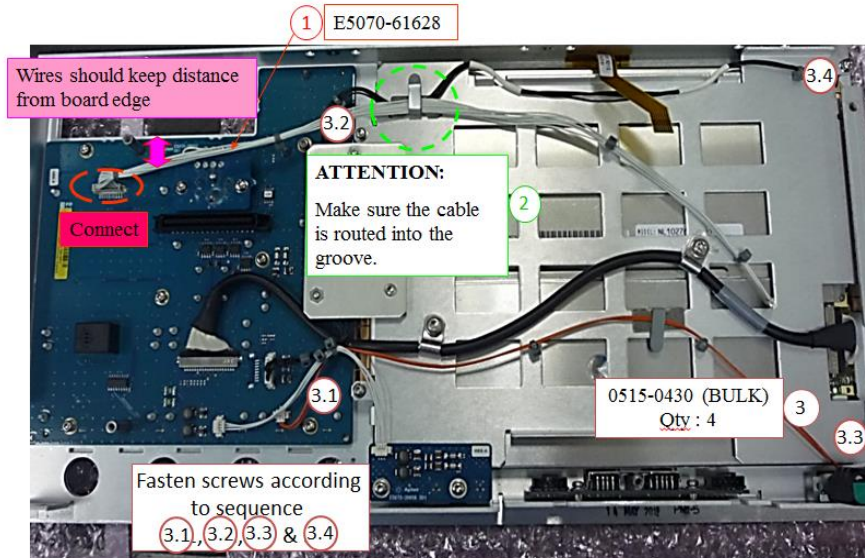

Figure 1-7

7. Connect the cable assemblies to the keyboard.

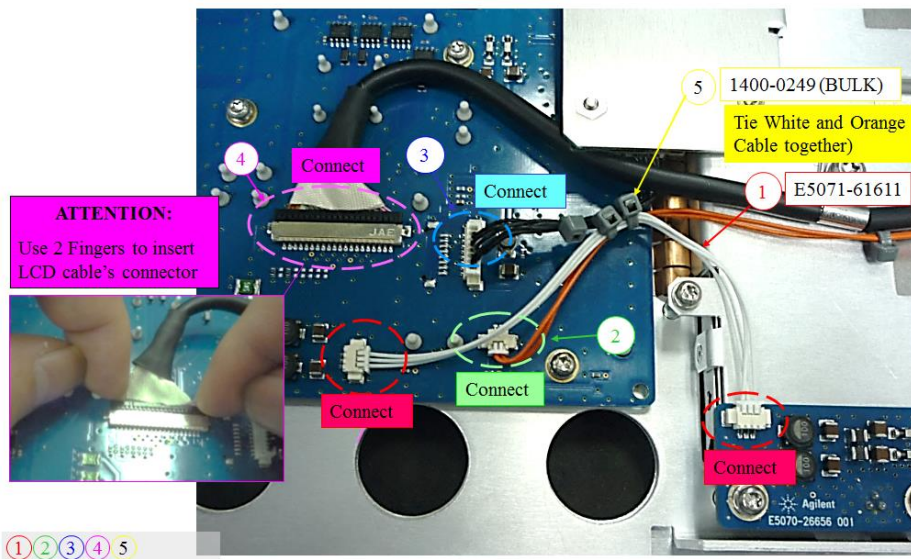

Figure 1-8

8. Shown would be the completed installation of the assemblies. Kindly ensure the connections of the cable assemblies are good and properly secured. Fasten the six screws in securing the shield (back cover) to the Front Panel Assembly.

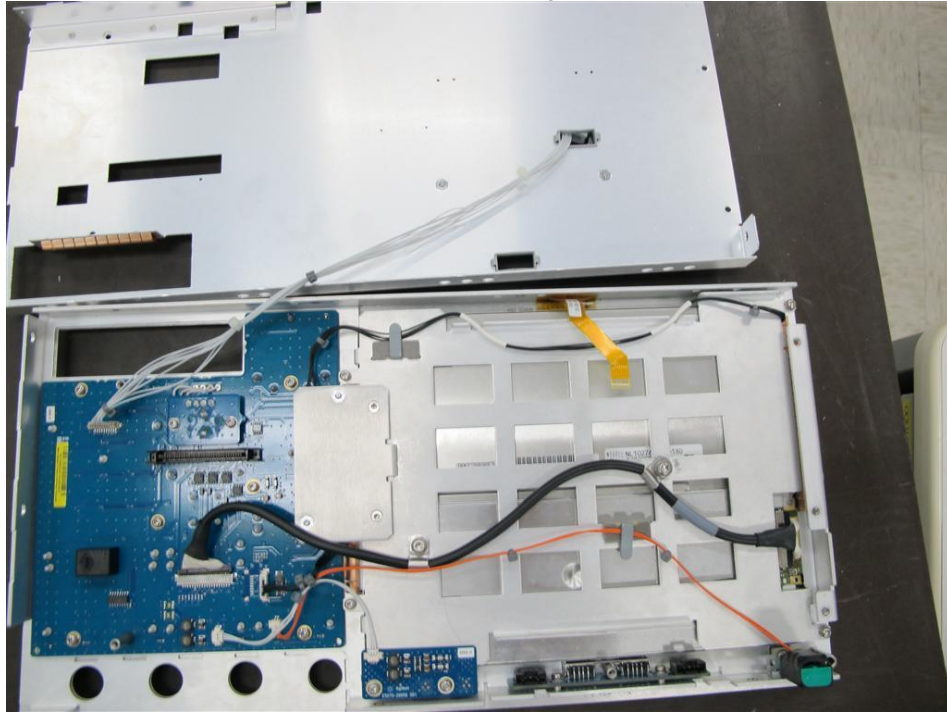

Figure 1-9

9. On Front Panel assembly shield (back cover), install the touch panel controller and the required cable clamps and gasket. Refer to figure 1-10, 1-11 for details.

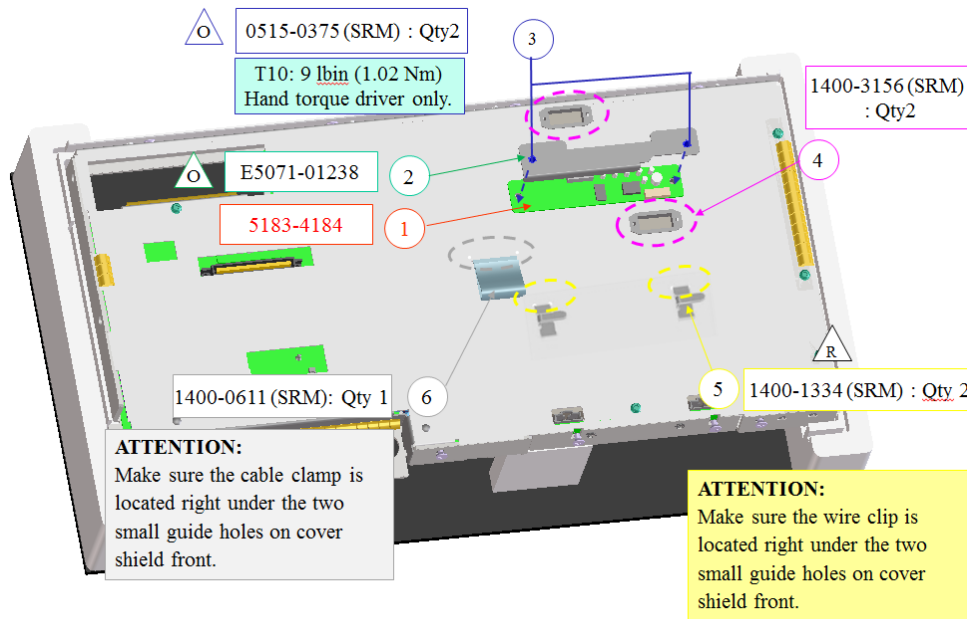

Figure 1-10

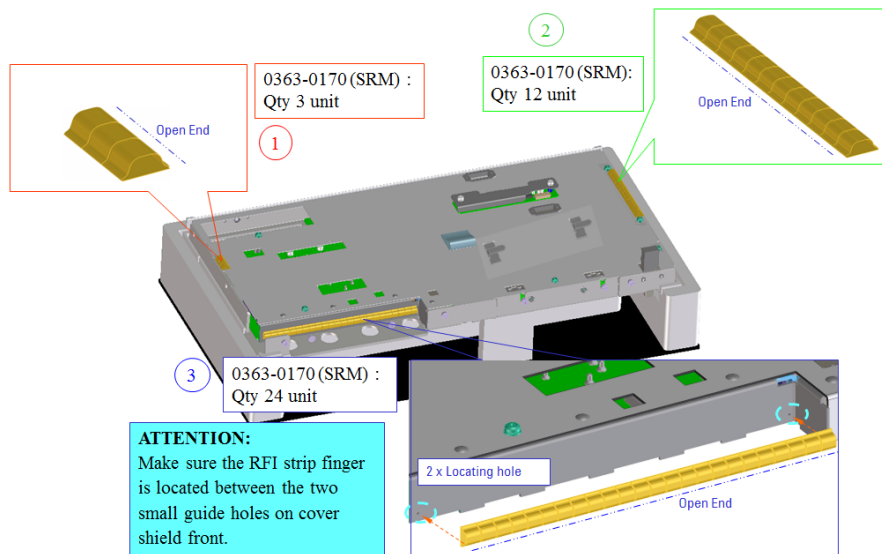

Figure 1-11

10. Figure 1-12 illustrate the final front panel assembly.

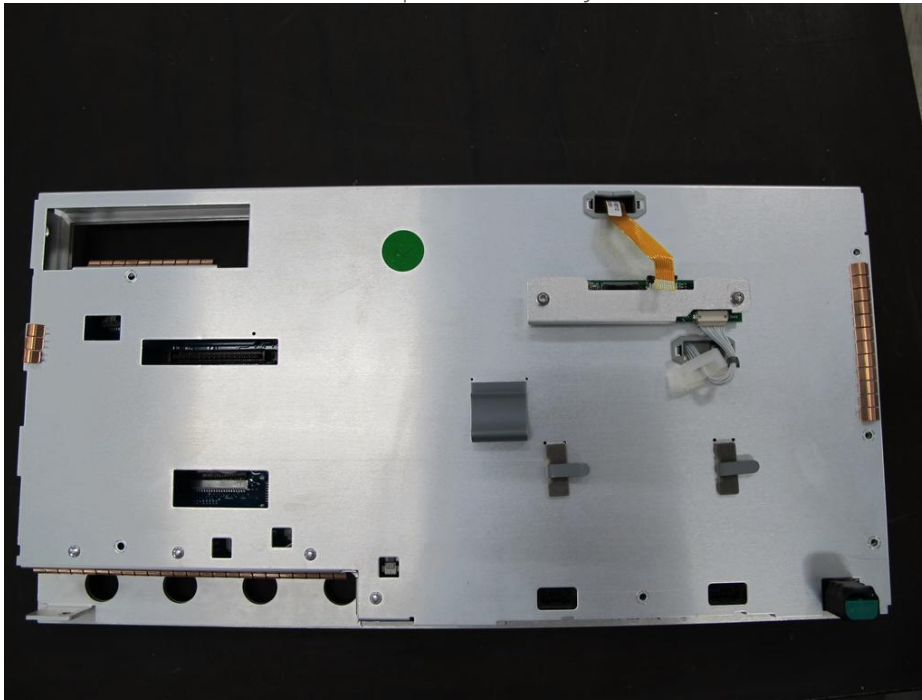

Figure 1-12

Post-repair requirements

Reinstall the front panel assembly by inverse procedure of removal.

Perform Touch Screen calibration and inspect on booting process. Execute the diagnostics test in verifying the functionality of Touch Panel and LCD display.

Refer to E5071C Service Guide Chapter 7 Post-Repair Procedures for detailed instructions.

For E5071C Opt 2D5 to 4K5 – Up to 20 GHz range

Situation:

For E5071C (serial prefix of MY461/SG461, MY462/SG462 and MY463/SG463), due to the part discontinuance by LCD display manufacturer, the E5070-60112 **LCD-Touch Panel Assembly** (with LCD Display with CCFL backlight) is no longer supplied.

The replacing part would be an LCD Touch Panel Display Assembly with LED backlight. In ensuring hardware compatibilities, there would be a list of associated parts required to be replaced whenever the LCD T/P assembly (LCD Display with CCFL backlight) is defective.

Solution/Action (For E5071C Opt 2D5 to 4K5 – Up to 20 GHz range)

LCD Removal

Refer to E5071C Service Guide (Chapter 6- Replacement Procedure → LCD Replacement) for the step-by-step procedure.

Front Panel Keyboard Removal

Refer to E5071C Service Guide (Chapter 6- Replacement Procedure → Front Panel Keyboard Replacement) for the detailed procedure.

Probe Power and Power Switch Board Removal

Refer to E5071C Service Guide (Chapter 6 → Probe Power and Power Switch Board Replacement (A56) for detailed instructions.

Note: Kindly take note to keep the original parts as some of the assemblies are reusable and replacement is not necessary.

For defective LCD T/P Assembly E5070-60112

In summary, whenever LCD T/P E5070-60112 is identified defective, replace the following parts altogether as they are mutually dependent:

1. LCD T/P assembly (with LED backlight display)
2. Inverter
3. Front Panel (label, panel sub, shield)
4. Cable assemblies
5. Screws etc.

In this case, apart from replacing the LCD T/P assembly with the replacement part, the inverter is required to be replaced in ensuring the compatibility with the new LCD T/P assembly (with LED backlight). Front panel needs to be replaced as the dimension and the new LCD T/P assembly screw size and location differs on the new LCD T/P display assembly (with LED backlight). Refer to table 2-1 for details.

For other failures (other than LCD T/P assembly E5070-60112)

If the defective part does not include LCD Touch Panel Assembly, proceed to replace the individual defective parts directly as usual. For instances, if the inverter 0950-4420 is found to be defective, replace the inverter alone will be sufficient. Similar applies to Touch Panel controller. Those parts are continuously supported and supplied until further notice. Refer to service guide for detailed instructions.

Table 2-1 Defective LCD T/P Assemblies - Support part strategy.

Table 2-1 depicts the support PN replacement strategy and their dependencies.

Legend:

Direct replacement: Replace one part.

Replace set: Set replacement with dependency. Replace all associated parts with “replace set” remarks.

Common: No part or design change.

New: Newly introduced part on new “LED backlight” design.

Repair kit is offered for ordering convenience in service center.

For Opt 2D5 to 4K5 (> 8.5GHz) freq. option, order **E5070-65114 Service-Kit, LCD Touch Panel Assembly, for E5071C-20GHz** (Not for Trade Sale)

Identified Defective Part	Types	Original installed PN	Description	Qty.	New PN	Description	Qty.	Remarks
Inverter (0950-4420)	Assemblies, Modules	0950-4420	Inverter	1	0950-4420WN	Inverter	1	Direct replacement
Touch Panel Controller (5183-4184)	Assemblies, Modules	5183-4184	Touch Panel Controller	1	5183-4184	Touch Panel Controller	1	Direct Replacement
LCD Touch Panel Assembly (E5070-60112)	Assemblies, Modules	E5070-60112	LCD Touch Panel Assembly	1	E5070-60113	LCD Touch Panel Assembly (With LED backlight)	1	Replace set
		E5071-00272	Panel Sub	1	E5070-00282	Panel Sub	1	Replace set
		E5070-00672	Cover Shield	1	E5071-00634	Cover Shield	1	Replace set

		0950-4420	Inverter	1	0950-5396	Inverter	1	Replace set
		E5071-01211	Inverter Bracket	1	E5071-01241	Inverter Bracket	1	Replace set
		E5071-00252 (Opt 2xx)	Front Panel	1	E5071-00252 (Opt 2xx)	Front Panel	1	Common
		E5070-00273 (Opt 2D5, 2K5)			E5070-00273 (Opt 2D5, 2K5)			
		E5071-00254 (Opt 4xx)			E5071-00254 (Opt 4xx)			
		E5070-00271 (Opt 4D5, 4K5)			E5070-00271 (Opt 4D5, 4K5)			
		[Refer to service guide page 190]			[Refer to service guide page 190]			
		5183-4184	Touch Panel Controller	1	5183-4184	Touch Panel Controller	1	Common
		E5071-01238	Touch Panel Controller Bracket	1	E5071-01238	Touch Panel Controller Bracket	1	Common
		E5070-66656	PCA Probe Power	1	E5070-66656	PCA Probe Power	1	Common
		E5070-66655	PCA Front USB	1	E5070-66655	PCA Front USB	1	Common
		E5070-61901	Standby Switch Wire Assembly	1	E5070-61901	Standby Switch Wire Assembly	1	Common

Cables	E5071-61616	LCD Display - Flat Cable assembly	1	E5070-61699	LCD Display - Flat Cable assembly	1	Replace set
	E5071-61608	Wire assembly, (Inverter to Keyboard)	1	E5061-61654	Wire assembly, LED Driver (Inverter to Keyboard)	1	Replace set
	(None)	(None) Original cable is pre-fitted with LCD T/P assembly	-	E5061-61653	Wire assembly, (Display backlight power)	1	New
	E5071-61611	Wire assembly, (PCA Probe Power to keyboard)	1	E5071-61611	Wire assembly, (PCA Probe Power to keyboard)	1	Common
	E5070-61628	Wire assembly, (Keyboard to T/P controller)	1	E5070-61628	Wire assembly, (Keyboard to T/P controller)	1	Common
Gasket	0363-0170	RFI-Gasket Strip-Fingers	79	0363-0170	RFI-Gasket Strip-Fingers	79	Common
Cable Tie	1400-0249	Cable tie	1	1400-0249	Cable tie	3	Common
Cable Clamp	1400-3377	Cable clamp (On cover shield)	2	1400-1334	Cable clamp (On cover shield)	2	Replace set
	1400-0611	Cable clamp (On cover shield)	1	1400-0611	Cable clamp (On cover shield)	1	Common
	1400-3156	Cable Clamp Nylon	2	1400-3156	Cable Clamp Nylon	2	Common

	Screws	(None)	(None)	-	0515-5711	Screw M4x0.7 - securing LCD Flat cable assembly	2	New
		(None)	(None)	-	0515-0430	Screw M3x0.5 - Underneath the inverter assembly (hidden)	2	New
		(None)	(None)	-	0515-1946	Screw M3x0.5 - Top of the inverter assembly (visible)	2	New
		0515-1402	Screw M3.5x0.6	4	0515-0430	Screw M3x0.5 - Securing the LCD T/P assembly to front panel	4	Replace set
		0515-0430	Screw M3x0.5	2	0515-0375	Screw M3x0.5 - T/P Controller	2	Replace set
		0515-0430	Screw M3x0.5	2	0515-430	Screw M3x0.5 - PCA Probe Power	2	Common
		0515-0430	Screw M3x0.5	8	0515-0430	Screw M3x0.5 - Keyboard	8	Common

Probe Power and Power Switch Board Removal

Refer to E5071C Service Guide (Chapter 6 → Probe Power and Power Switch Board Replacement (A56) for detailed instructions.

LCD Replacement.

1. Install the keyboard on the new front panel sub as shown in figure 2-1.

Note: The front panel, panel sub and cover shield are required to be replaced due to dimension changes. Front panel frequency label has to be purchased separately according to unit frequency options.

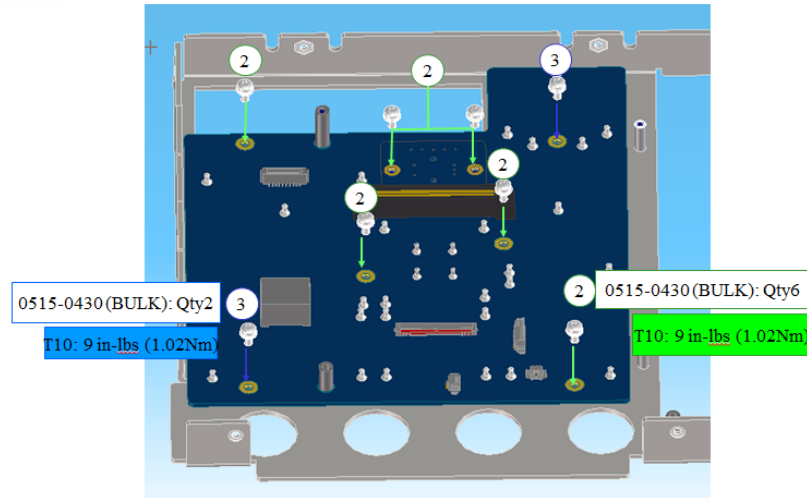

Figure 2-1

2. Install the gaskets as shown in Figure 2-2. Figure 2-3 illustrates the Front panel with the keyboard installed.

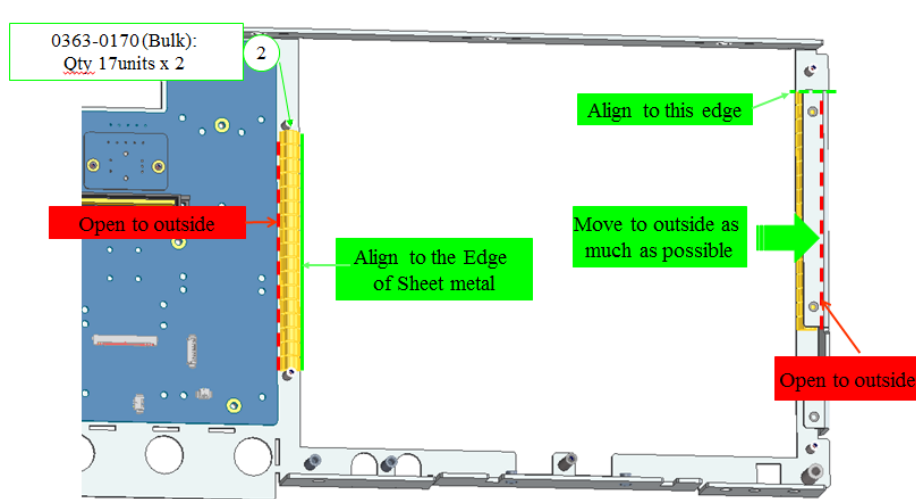

Figure 2-2

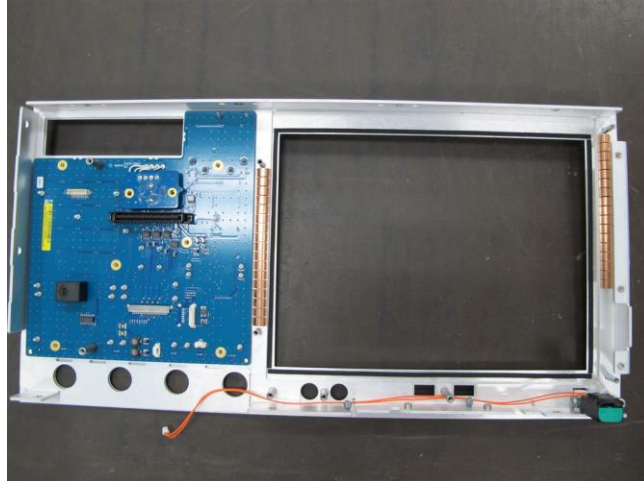

Figure 2-3

3. Install the inverter on the bracket before connect the cable assembly to both ends as shown in figure 2-4

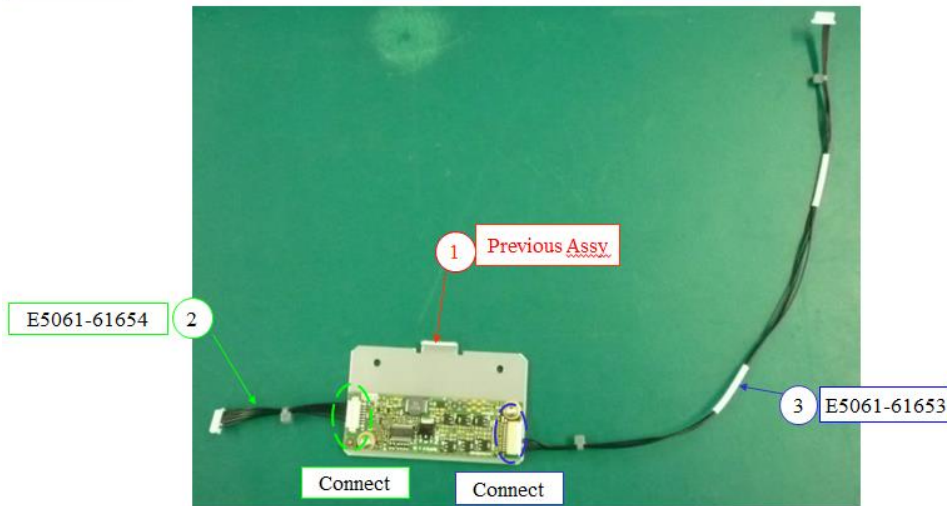

Figure 2-4

4. Install the inverter assembly onto the new CLD T/P display assembly (with LED backlight). Refer to figure 2-5 for details.

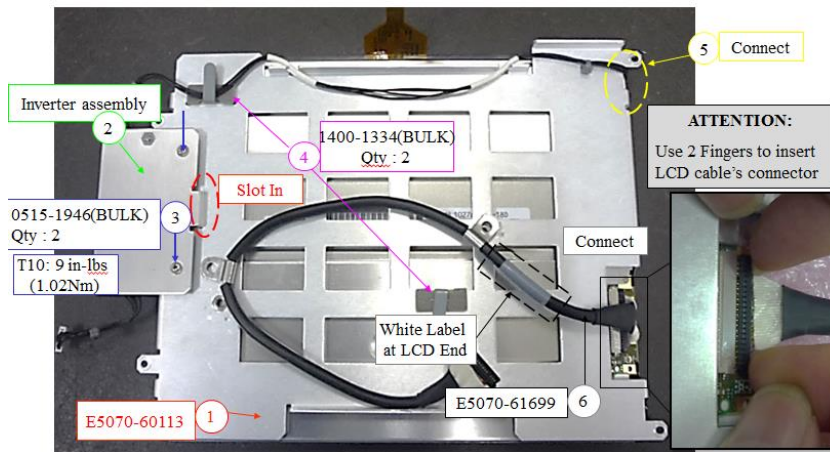

Figure 2-5

5. Route the LCD display assembly cables accordingly.

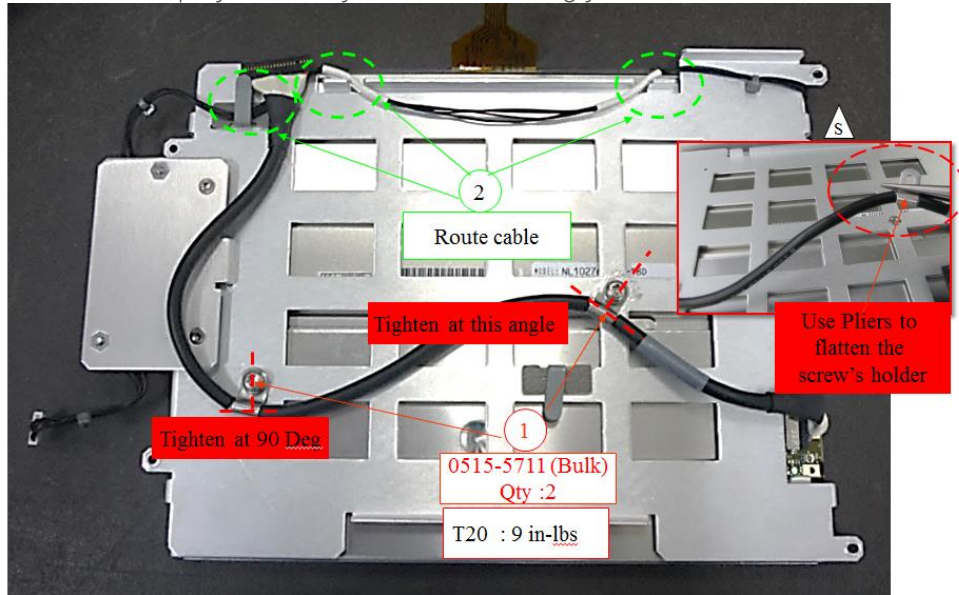

Figure 2-6

6. Install the LCD T/P Display Assembly onto the LCD Front Panel. Fasten the screws according to the following sequence. Connect all cable assemblies as shown in figure 2-7.

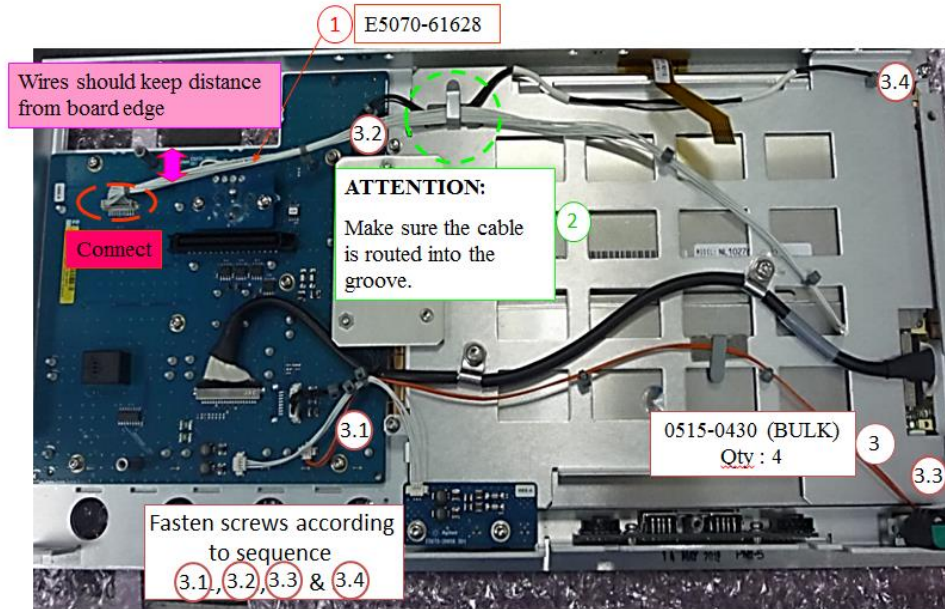

Figure 2-7

7. Connect the cable assemblies to the keyboard.

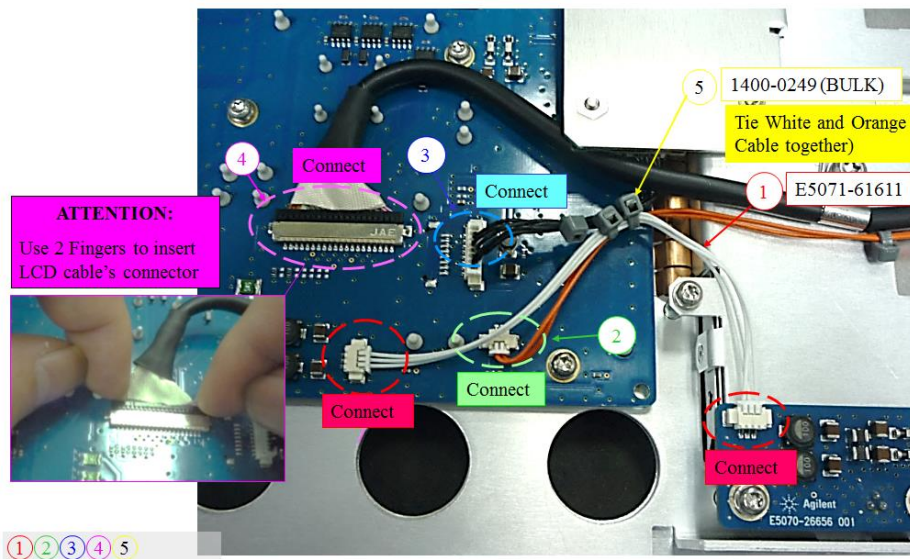

Figure 2-8

8. Shown would be the completed installation of the assemblies. Kindly ensure the connections of the cable assemblies are good and properly secured. Fasten the six screws in securing the shield (back cover) to the Front Panel Assembly.



Figure 2-9

9. On Front Panel assembly shield (back cover), install the touch panel controller and the required cable clamps and gasket. Refer to figure 2-10, 2-11 for details.

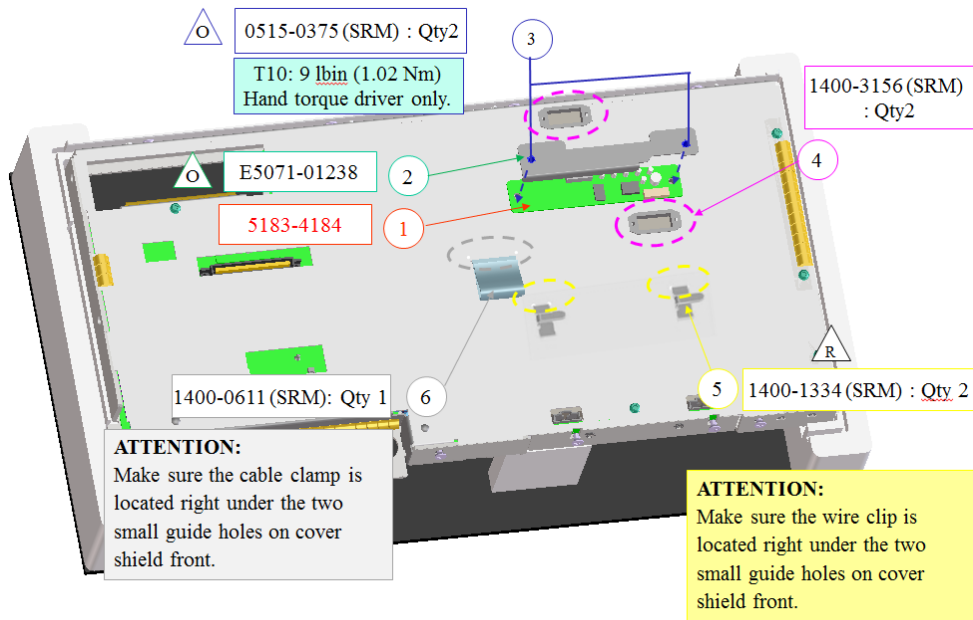

Figure 2-10

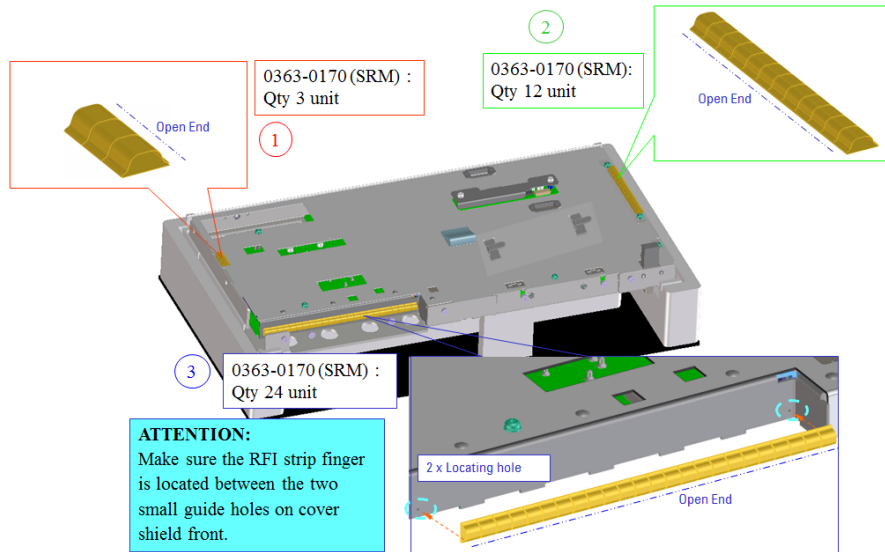

Figure 2-11

10. Figure 2-12 illustrate the final front panel assembly.

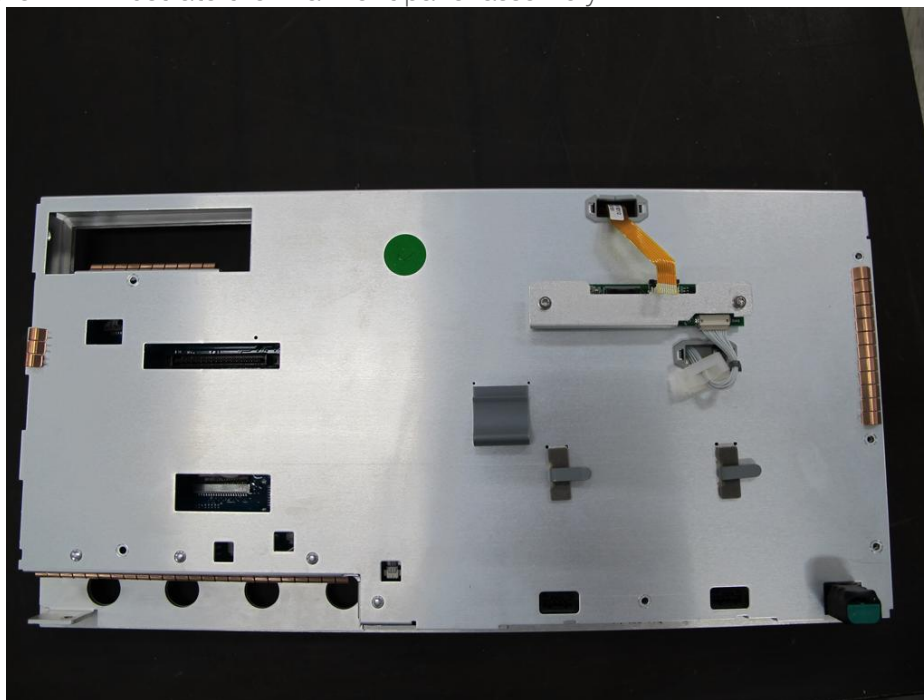

Figure 2-12

Post-repair requirements

Reinstall the front panel assembly by inverse procedure of removal. Perform Touch Screen calibration and inspect on booting process. Execute the diagnostics test in verifying the functionality of Touch Panel and LCD display.

Refer to E5071C Service Guide Chapter 7 Post-Repair Procedures for detailed instructions.

Appendix

Listed are the materials for the respective service kits.

E5070-65112 Service-Kit, LCD Touch Panel Assembly, for E5071C

Part Number	Qty.	Description
0363-0170	1.5	RFI-Gasket Strip-Fingers Beryllium-Copper Bright dipped finish
0371-3953	1	Key cap, Square corporate white-HP
04191-08000	1	Spring
0515-0375	2	Screw-Machine W/Crest-Cup-Con-Washer Pan-HD Torx-T10 M3X0.5 16mm-LG SST-300 Passivated
0515-0430	28	Screw-Machine W/Crest-Cup-Con-Washer Pan-HD Torx-T10 M3X0.5 6mm-LG SST-300 Passivated
0515-1382	11	Screw-Machine W/Patch-LK 90-DEG-Flat-HD Torx-T15 M3.5X0.6 6mm-LG SST-302 Passivated
0515-1946	2	Screw-Machine 90-DEG-flat-HD Torx-T10 M3X0.5 6mm-LG SST 300 passivated
0515-2028	2	Screw-Machine with Patch-Lock 90-DEG-Flat-HD Torx-T8 M2.5X0.45 6mm-LG SST-300 Passivated
0515-5711	2	Screw-Machine W/Crest-Cup-Con-Washer Pan-HD Torx-T20 M4X0.7 4mm-LG SST-302
0950-5396	1	DC-DC Converter Driver 12V input LED backlight module
1400-0249	1	Cable-Tie self-Locking 91-mil-Wide Nylon Gray
1400-0611	1	Clamp-Flange-Cable pressure sensitive Adhesive mounting 1-in-LG 1-in-Wide 250-mil-HT Poly Vinyl chloride (PVC)
1400-1334	4	Clamp-Cable snap-in pressure sensitive Adhesive mounting 24mm-LG 10mm-Wide Steel Zinc plated
1400-3156	2	Clamp-Cable Buckle-Locking 30.4mm-LG 13.4mm-Wide Nylon 6/6 Gray
5183-4184	1	Printed Circuit Board Assembly, Cntr touch panel
E5061-61653	1	Wire Assembly, Display Backlight Power
E5061-61654	1	Wire Assembly, LED Driver
E5070-60113	1	LCD-Touch Panel Assembly
E5070-61628	1	Wire assembly, Wire assy
E5070-61699	1	Cable assembly, LCD Display
E5070-61901	1	Wire assembly, wire assembly with switch
E5070-66655	1	Printed Circuit Board Assembly, Pb-free, FRONT USB
E5070-66656	1	Printed Circuit Board Assembly, Pb-free, PROBE POWER
E5071-00262	1	Panel, Front Sub
E5071-00633	1	Cover, Shield front
E5071-01238	1	Bracket for Touch Panel Driver Board
E5071-01241	1	Bracket LED Driver Board
E5071-04004	1	Cover USB Large
E5071-61611	1	Wire Assembly

E5070-65114 Service-Kit, LCD Touch Panel Assembly, for E5071C-20GHz

Part Number	Qty.	Description
0363-0170	1.5	RFI-Gasket Strip-Fingers Beryllium-Copper Bright dipped finish
0371-3953	1	Key cap, Square corporate white-HP
04191-08000	1	Spring
0515-0375	2	Screw-Machine W/Crest-Cup-Con-Washer Pan-HD Torx-T10 M3X0.5 16mm-LG SST-300 Passivated
0515-0430	28	Screw-Machine W/Crest-Cup-Con-Washer Pan-HD Torx-T10 M3X0.5 6mm-LG SST-300 Passivated
0515-1382	11	Screw-Machine W/Patch-LK 90-DEG-Flat-HD Torx-T15 M3.5X0.6 6mm-LG SST-302 Passivated
0515-1946	2	Screw-Machine 90-DEG-flat-HD Torx-T10 M3X0.5 6mm-LG SST 300 passivated
0515-2028	2	Screw-Machine with Patch-Lock 90-DEG-Flat-HD Torx-T8 M2.5X0.45 6mm-LG SST-300 Passivated
0515-5711	2	Screw-Machine W/Crest-Cup-Con-Washer Pan-HD Torx-T20 M4X0.7 4mm-LG SST-302
0950-5396	1	DC-DC Converter Driver 12V input LED backlight module
1400-0249	1	Cable-Tie self-Locking 91-mil-Wide Nylon Gray
1400-0611	1	Clamp-Flange-Cable pressure sensitive Adhesive mounting 1-in-LG 1-in-Wide 250-mil-HT Poly Vinyl chloride (PVC)
1400-1334	4	Clamp-Cable snap-in pressure sensitive Adhesive mounting 24mm-LG 10mm-Wide Steel Zinc plated
1400-3156	2	Clamp-Cable Buckle-Locking 30.4mm-LG 13.4mm-Wide Nylon 6/6 Gray
5183-4184	1	Printed Circuit Board Assembly, Cntr touch panel
E5061-61653	1	Wire Assembly,Display Backlight Power
E5061-61654	1	Wire Assembly,LED Driver
E5070-60113	1	LCD-Touch Panel Assembly
E5070-61628	1	Wire assembly, Wire assy
E5070-61699	1	Cable assembly, LCD Display
E5070-61901	1	Wire assembly, wire assembly with switch
E5070-66655	1	Printed Circuit Board Assembly, Pb-free, FRONT USB
E5070-66656	1	Printed Circuit Board Assembly, Pb-free,PROBE POWER
E5071-00262	1	Panel, Front Sub
E5071-00633	1	Cover, Shield front
E5071-01238	1	Bracket for Touch Panel Driver Board
E5071-01241	1	Bracket LED Driver Board
E5071-04004	1	Cover USB Large
E5071-61611	1	Wire Assembly

Revision History:

Date	Service Note Revision	Author	Reason for Change
29-Jan-2014	E5071C-31	ls	As Published
23-Oct-2014	E5071C-31A	jm	Corrected Panel Sub and Front Panel part-numbers
18-July-2017	E5071C-31B	ls	Added LCD service kit part numbers (Not for Trade Sale) for Keysight service center parts purchase convenience.