

S E R V I C E N O T E

SUPERSEDES: None

**Agilent E5100A/B Network Analyzer**

**Serial Numbers:**

E5100A: JP1KC00101 / JP5KC02487  
 E5100B: JP1KC00101 / JP5KC00644

**WARNING**

**A broken AC inlet may potentially result in a electric shock hazard.**

**Duplicate Service Notes:** E5100B-30-S  
 E5100A-30-S

**To Be Performed By:** Agilent-Qualified Personnel

**Parts Required:**

Agilent P/N	Description	Qty	Memo
5183-4112 (*)	Silicon Seal	1	Solution 1
5080-3270	Label	1	Solution 1
E5100-00223	Rear Panel	1	Solution 2
2110-1303	Fuse	1	Solution 2

(\*) Store in a cool, dry place out of direct sunlight.

*Continued*

DATE: September 2000

**ADMINISTRATIVE INFORMATION**

SERVICE NOTE CLASSIFICATION:			
<b>PRIORITY SAFETY</b>			
ACTION CATEGORY: <b>IMMEDIATELY</b>		STANDARDS: 0.5 Solution #1 or 2.0 Solution #2 hours LABOR	
LOCATION CATEGORY:	<input type="checkbox"/> ON-SITE <input checked="" type="checkbox"/> SERVICE CENTER	SERVICE INVENTORY:	<input type="checkbox"/> RETURN <input type="checkbox"/> SCRAP <input type="checkbox"/> SEE TEXT
		USED PARTS:	<input type="checkbox"/> RETURN <input checked="" type="checkbox"/> SCRAP <input type="checkbox"/> SEE TEXT
AVAILABILITY:	ALWAYS	AGILENT RESPONSIBLE UNTIL : ALWAYS	
AUTHOR: HU	ENTITY: 3355	ADDITIONAL INFORMATION: 02G Repair Class	

**Situation:**

The AC inlet (P/N 1252-6951) has the potential to slip out of the instrument's rear panel slot if the AC power cord is forcefully pulled in a diagonal direction. When this happens, an exposed connection on the AC inlet module may touch the rear panel of the instrument and cause an electrical short if the AC power cord is still connected to the AC power outlet. See Figure 1.

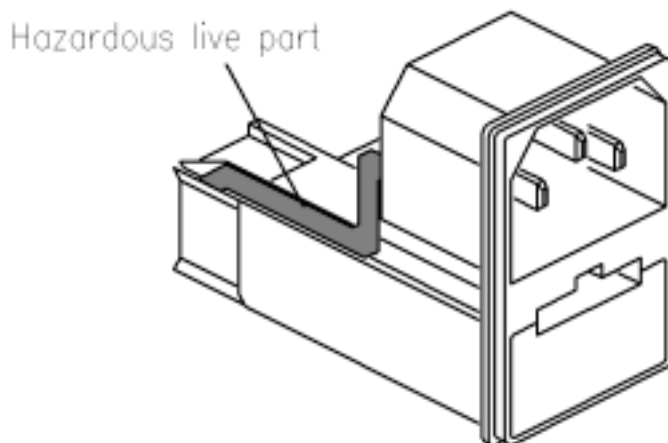

**Figure 1. AC Inlet Connector**

In the worst case, there is also a possibility of an electric shock hazard to the user if the user completes a circuit between the instrument panel and another grounded connection while the AC power cord is still connected to the AC power outlet.

**Solution / Action:**

There are two possible solutions; one if the AC inlet is still seated in the instrument's rear panel, and a second if the AC inlet has been yanked out of the slot.

Repair instructions in HTML format are available over the Agilent Intranet at URL

[http://kobemktg.jp/agilent.com/field\\_eng/service/](http://kobemktg.jp/agilent.com/field_eng/service/)  
(CT-PGU Kobe Service Information)

Click on "Service FAQ", click on "AC Inlet\_Mode No."

**Solution 1. AC Inlet Still Intact.**

- Remove the AC power cable from the AC power outlet and the product.
- Remove the top, bottom, and side covers.
- Seal the hot line terminal on the AC inlet with silicon paste (P/N 5183-4112).
- Reinforce the connection between the AC inlet and the rear panel with silicon paste.
- Perform Self Test to verify instrument operation.

*Continued*

After completing the above instructions, stick the label (P/N 5080-3270) next to the AC Inlet on the rear panel as a mark that this repair has been completed. See Figure 2.

### **Solution 2. AC Inlet Broken**

- Remove the AC power cable from the AC power outlet and the product.
- Remove the top, bottom, and side covers.
- Replace the rear panel assembly with P/N E5100-00223
- Install the new fuse P/N 2110-1303.
- Perform Self Test to verify instrument operation

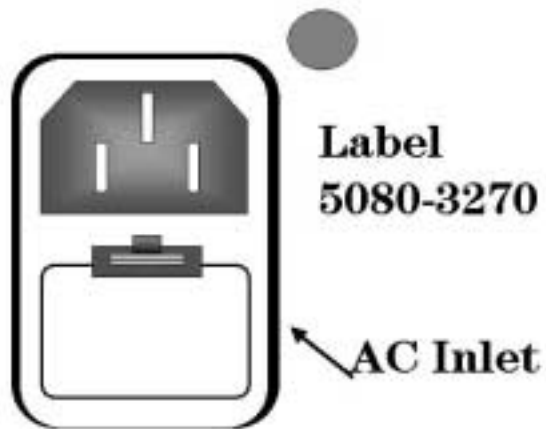

**Fig. 2**

**Figure 2. Repair Completed Label**